



Gianni
Ferrari

CRUISER

TURBO TURBO

TURBO^T

TURBO^T



CATALOGO PARTI DI RICAMBIO
CATALOGUE PIECES DETACHEES
ERSATZEILKATALOG
PARTS MANUAL

07.01.2016

INDICE • PART LIST • TABLES DES MATIERES • STÜCK LISTE

TAV. 01	TELAIO FRAME CHASSIS CHASSIS	TAV. 13	SERBATOIO OLIO / SUPPORTO POMPE OIL TANK / PUMP GEARBOX RESERVOIR D'HUILE / BOITIER POMPE ÖLTANK / PUMPENAUFLEGE
TAV. 02	PARAURTI / SERBATOIO / STAFFE / BATTERIA BUMPER / FUEL TANK / BRACKETS / BATTERY PARE-CHOCS / RESERVOIR / ETRIERES / BATTERIE STOßSTANGEN / TANK / BÜGEL / BATTERIE	TAV.14	POMPE E MOTORI IDRAULICI HYDRAULIC MOTORS AND PUMPS POMPES ET MOTEURS HYDRAULIQUES PUMPEN UND HYDRAULIKMOTOREN
TAV. 03	INNESTO P.D.P. CLUTCH CONTROL ASSEMBLY EMBRAYAGE P.D.F. EINSCHALTKUPPLUNG DER ZAPFWELLE	TAV.15	IDROGUIDA E SERVOCOMANDI HYDRAULIC STEERING GEAR AND SERVO CONTROL POMPE HYDRAULIQUE DE DIRECTION ET SERVO-COMMANDES HYDRAULISCHE LENKUNG UND SERVOSTEUERUNG
TAV. 04	TURBINA BLOWER ASSEMBLY TURBINE GEBLÄSE	TAV.16	CIRCUITO IDRAULICO AUSILIARIO A AUX HYDRAULIC CIRCUIT A CIRCUIT HYDRAULIQUE AUXILIAIRE A ZUSATZHYDRAULIK A
TAV. 05	CONTENITORE GRASS COLLECTOR BAC RECUPERATEUR GRASBEHÄLTER	TAV.17	CIRCUITO IDRAULICO AUSILIARIO B AUX HYDRAULIC CIRCUIT B CIRCUIT HYDRAULIQUE AUXILIAIRE B ZUSATZHYDRAULIK B
TAV. 06	SNODO STERZANTE POSTERIORE REAR STEERING GEARDRIVE BOITIER DIRECTEUR ARRIERE HINTERSTEUERGELENK	TAV.18	ELEVATORE - STRUTTURA HIGH DUMP - STRUCTURE ELEVATION DU BAC - STRUCTURE HOCHENTLEERUNG - AUFBAU
TAV. 07	SCATOLA CENTRALE POSTERIORE REAR CENTER GEARBOX BOITIER CENTRAL ARRIERE HINTERMITTELGEHÄUSE	TAV.19	RADIATORI OLIO E A/C OIL RADIATOR AND AIR CONDITIONED RADIATEURS HUILE ET AIR CLIMATISE ÖLKÜHLER UND KLIMAAANLAGE
TAV. 08	ASSALE POSTERIORE T2 REAR AXLE T2 ESSIEU ARRIERE T2 HINTERACHSE T2	TAV.20	GRUPPO CABINA 1 CAB GROUP 1 GROUPE CABINE 1 KABINE BAUGRUPPE 1
TAV. 09	RIDUTTORE ANTERIORE FRONT GEARDRIVE BOITIER AVANT VORDERUNTERSETZUNGSGETRIEBE	TAV.21	GRUPPO CABINA 2 CAB GROUP 2 GROUPE CABINE 2 KABINE BAUGRUPPE 2
TAV. 10	SCATOLA CENTRALE ANTERIORE FRONT CENTER GEARBOX BOITIER CENTRAL AVANT VORDERMITTELGEHÄUSE	TAV.22	CRISTALLI LATERALI SIDE WINDOWS VITRE DE PORTE LATERAL SEITENSCHIEBEN
TAV. 11	MOTORE ENGINE MOTEUR MOTOR	TAV.23	CRISTALLO ANTERIORE E TERGICRISTALLO FRONT WIND + WINDSHIELD PARE-BRISE ET ESSUIE-GLACE FRONTSCHIEBE UND SCHEIBENWISCHER
TAV. 12	COMPONENTI MOTORE ENGINE COMPONENT PARTS PARTIE COMPOSANTES MOTEUR MOTORBESTANDTEILE		

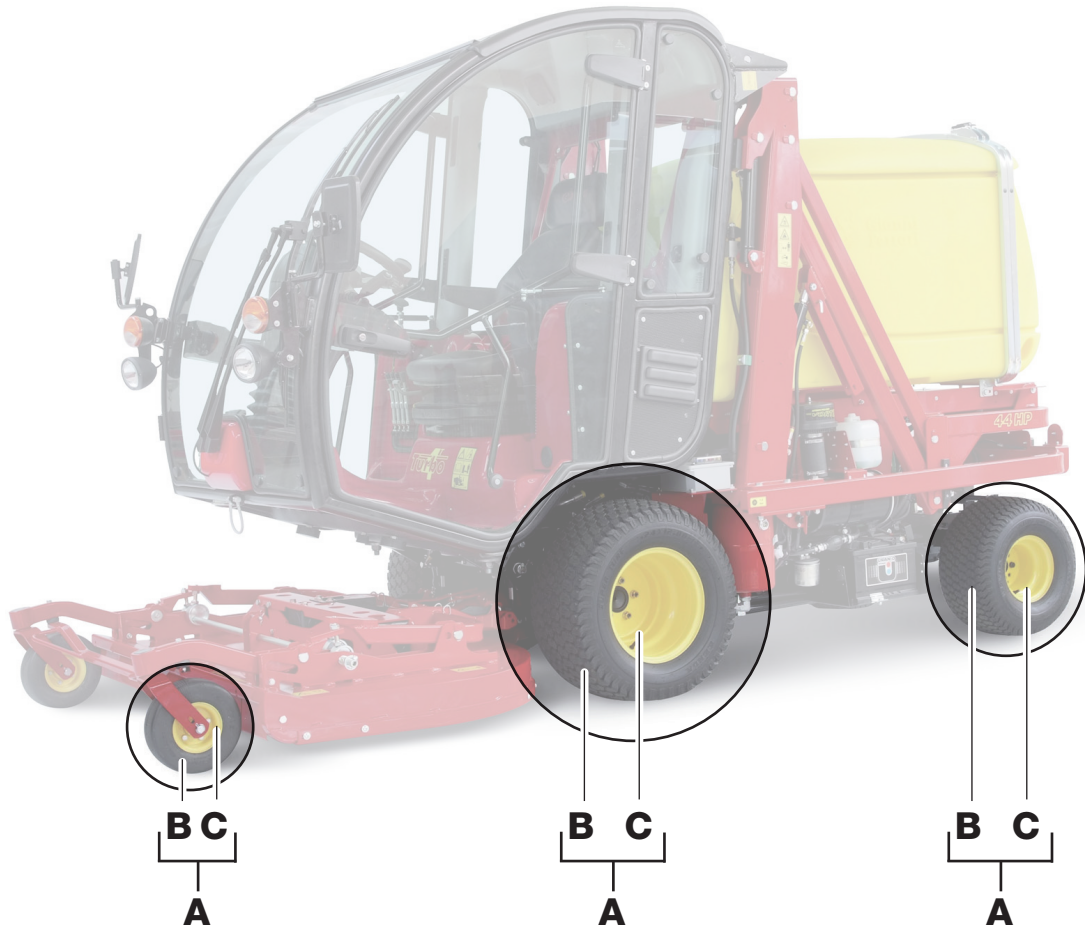
Ruote - Wheels - Roues - Rader

					A	B	C
ANTERIORI / FRONT / AVANT / VORDERRÄDER							
24	1200	12	8PR	SUPERTURF	00.72.00.0080	00.59.00.0102	00.16.00.0131
POSTERIORI / REAR / ARRIER / VHINTERRÄDER							
20	1000	8	4PR	SUPERTURF	00.72.00.0152	00.59.00.0072	=====
RASAERBA / DECK / TONDEUSE / MÄHWERK							
8	300		4	SOLID	00.72.00.0203	=====	00.16.00.0040
9	350		4	SOLID	00.72.00.0204	00.59.02.0005	00.16.00.0040

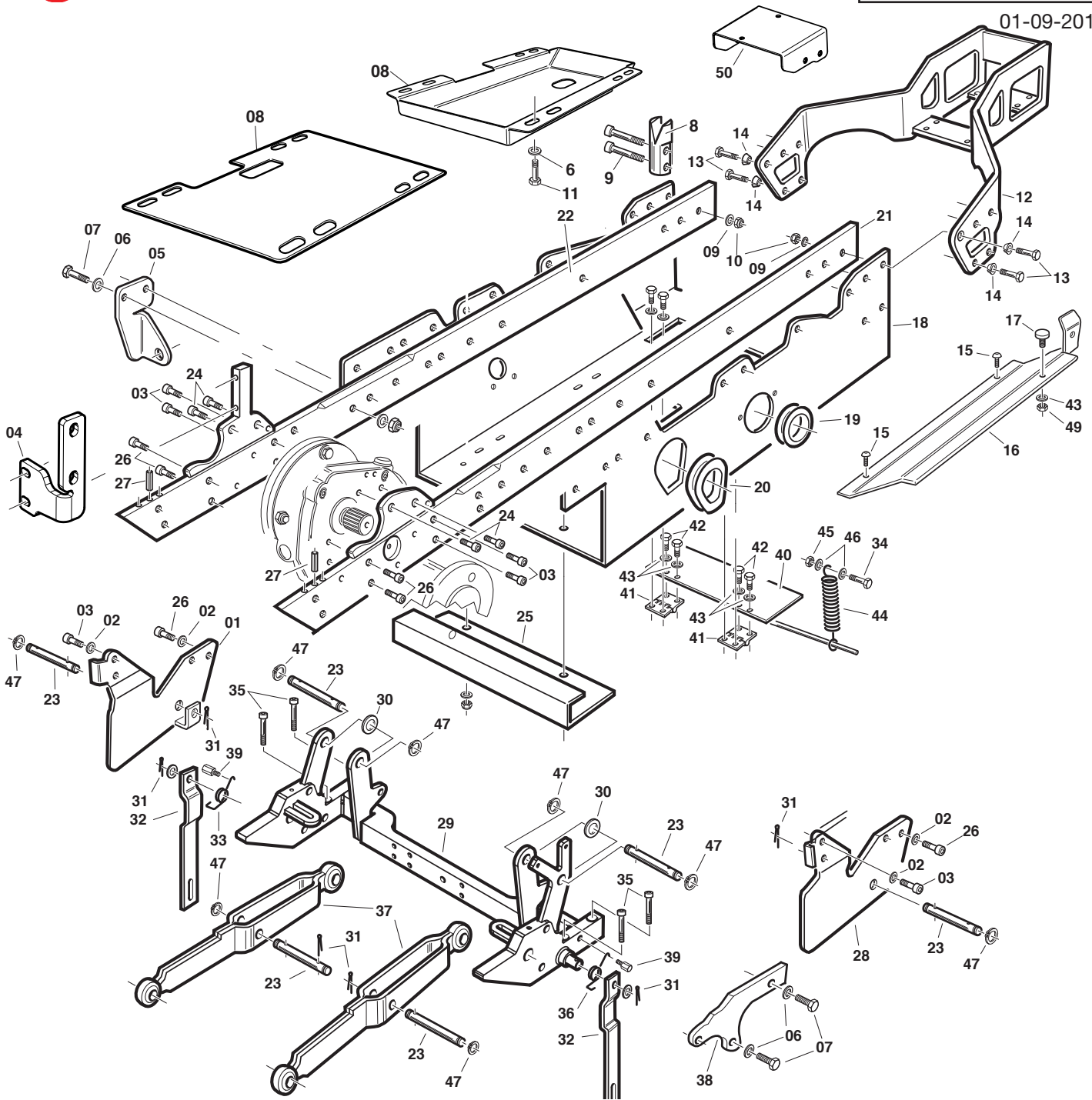

REF.	LEG.	CODE	Q.TY	REF.	LEG.	CODE	Q.TY	REF.	LEG.	CODE	Q.TY
1		01.50.00.7400	1	17		00.74.00.0017	1	34		00.92.05.1100	4
2		00.68.04.0100	8	18		01.50.00.5990	1	35		00.90.07.0141	4
3		00.90.07.0121	8	19		00.11.01.1000	0,4	36		00.47.00.0280	1
4		01.60.00.0348	1	20		00.11.01.1000	0,31	37		01.50.00.7420	2
5		01.50.00.7770	1	21		01.50.00.5981	1	38		01.60.00.0077	1
6		00.68.01.0040	3	22		01.50.00.5982	1	39		01.40.00.3760	2
7		00.92.06.0140	1	23		01.40.00.2690	6	40		01.50.00.0198	1
8	TURB	01.60.00.1087	1	24		00.90.07.0082	4	41		00.07.02.0020	2
8	ASP	01.60.00.1124	1	25		01.50.00.3095	1	42		00.92.03.1070	8
9		00.68.01.0050	4	26		00.90.07.0101	6	43		00.68.01.0020	1
10		00.26.04.0080	4	27		00.83.14.0036	2	44		00.47.00.0061	1
11		00.92.06.0100	2	28		01.50.00.7410	1	45		00.26.02.0060	1
12		01.50.00.6000	1	29		01.50.00.0197	1	46		00.68.01.0030	6
13		00.92.07.0090	10	30		00.68.01.0070	2	47		00.03.10.0016	1
14		00.26.04.0080	10	31		00.18.04.0075	6	48		00.92.03.0170	1
15		00.92.05.1010	2	32		01.50.00.7570	2	49		00.26.05.0040	1
16		01.50.00.0156	1	33		00.47.00.0290	1	50		01.50.01.2759	1



Gianni Ferrari

1152084

Cruiser-02

T2-T2T-T4-T4T

01-09-2013

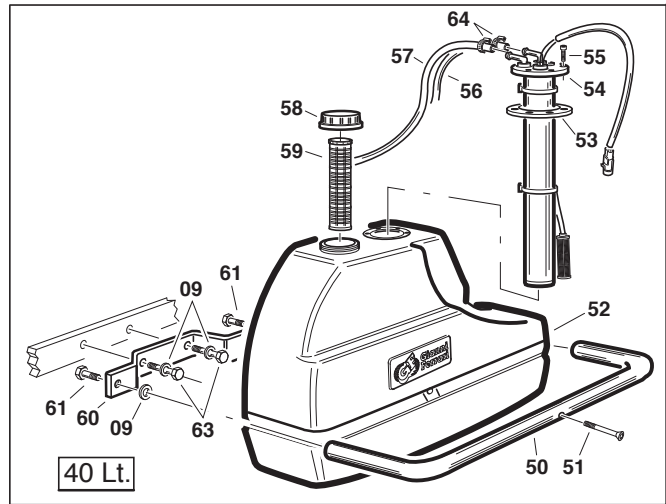
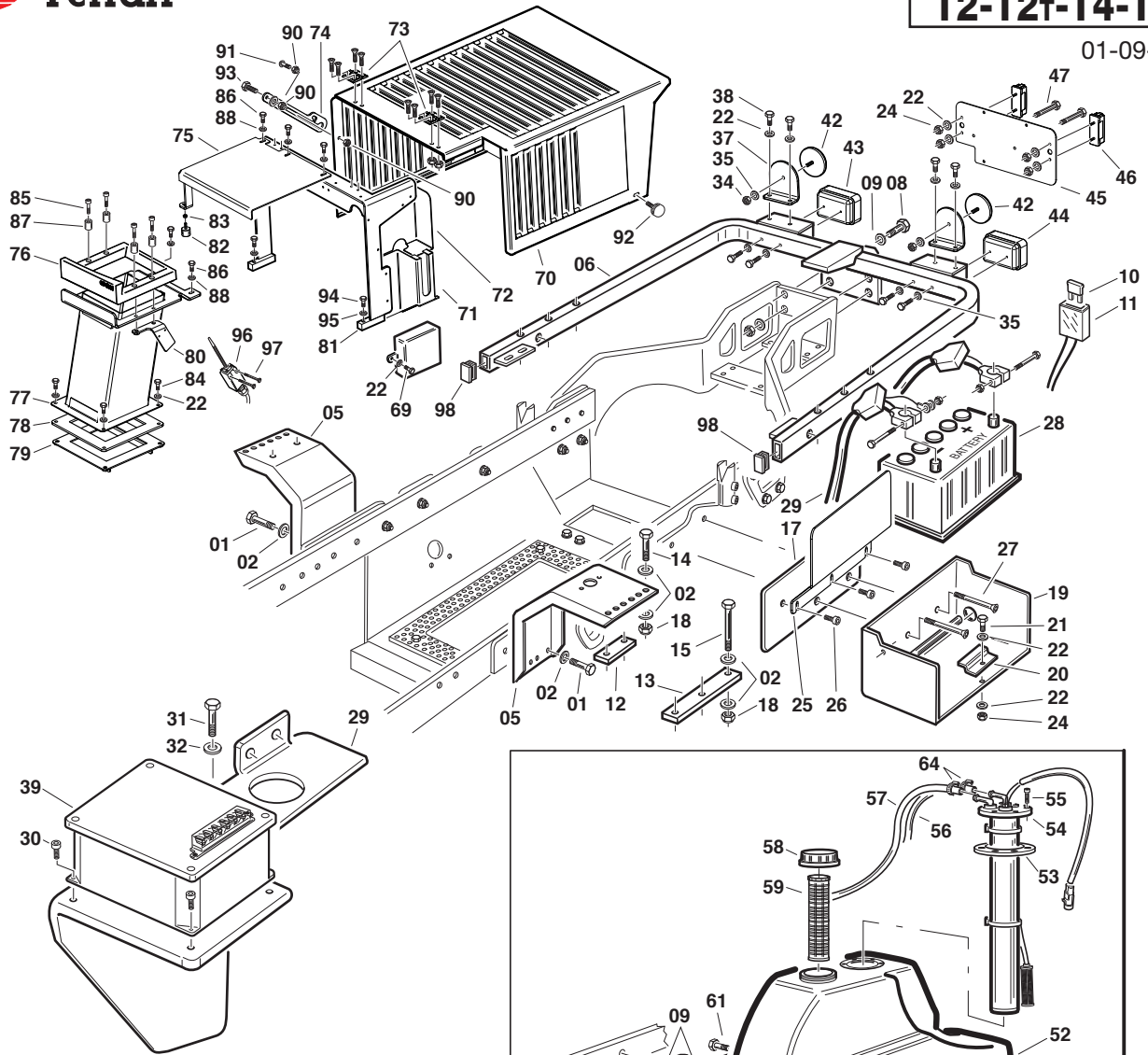

REF.	LEG.	CODE	Q.TY
1		00.92.07.0110	8
2		00.68.05.0010	8
5		01.50.00.2341	2
6		01.50.00.5360	1
6	LED	01.50.00.5358	1
7		01.60.00.1083	1
8		00.92.06.0100	4
9		00.68.01.0040	16
10		00.40.00.0809	1
11		00.40.00.0811	1
12		01.50.00.5080	2
13		01.50.00.6270	2
14		00.68.01.0050	30
15		00.92.07.0130	6
16		00.92.07.0220	6
17		01.50.01.2763	1
18		00.26.04.0080	18
19		01.50.00.5281	1
20		01.60.20.0069	1
21		00.92.03.1060	1
22		00.68.01.0020	1
24		00.26.04.0040	1
25		01.60.00.0640	1
26		00.90.04.0060	3
27		00.95.06.0150	2
28		00.09.00.0040	1
29		01.60.00.0159	1
30		00.90.04.0070	3
31		00.92.06.1090	2
32		00.68.02.0070	2
33		00.40.00.0159	1
34		00.26.04.0030	4
35		00.68.02.0020	10
36		00.92.02.1070	2
37		01.60.00.0619	1

REF.	LEG.	CODE	Q.TY
38		00.90.04.3070	4
39		00.40.00.0038	1
42		00.40.00.0990	2
43		00.40.00.0980	1
43	LED RH	00.40.00.0064	1
44		00.40.00.0980	1
44	LED LH	00.40.00.0065	1
45		01.60.00.0341	1
46		00.40.00.0550	2
47		00.95.04.0150	2
50		01.50.01.1600	1
51		00.95.04.0110	1
52		00.75.00.0056	1
53		00.07.01.0170	1
54		00.75.00.0161	1
55		00.94.06.7060	6
56		00.89.02.0000	2m
57		00.89.01.0000	1.8m
58		00.75.00.0012	1
59		00.75.00.0013	1
60		01.60.00.0570	1
61		00.92.06.1120	2
63		00.92.06.0110	2
64		00.29.02.0016	2
69		00.40.00.2400	1
70		01.50.01.2754	1
71		01.50.00.0157	1
72		01.60.00.0343	1

REF.	LEG.	CODE	Q.TY
73		00.99.00.0240	2
74		01.60.00.0644	1
75		01.50.01.2756	1
76		01.29.00.0140	1
77		01.50.01.2755	1
78		01.29.00.0162	1
79		01.50.01.2764	1
80		01.50.00.0215	1
81		01.50.00.0155	1
82		00.74.03.0050	1
83		00.26.00.0040	1
84		00.92.03.1060	4
85		00.90.04.3130	4
86		00.92.03.1040	9
87		01.40.00.4770	4
88		00.68.02.0030	9
89		00.95.04.0030	8
90		00.26.05.0060	3
91		00.26.02.0060	3
92		00.45.01.0035	1
93		00.90.06.3100	1
94		00.92.05.1100	2
95		00.60.01.0030	2
96		00.40.00.0039	1
97		00.90.02.0120	2
98		00.07.01.0010	2
99		00.26.04.0030	3
100		00.68.02.0020	3
101		00.90.05.3020	3

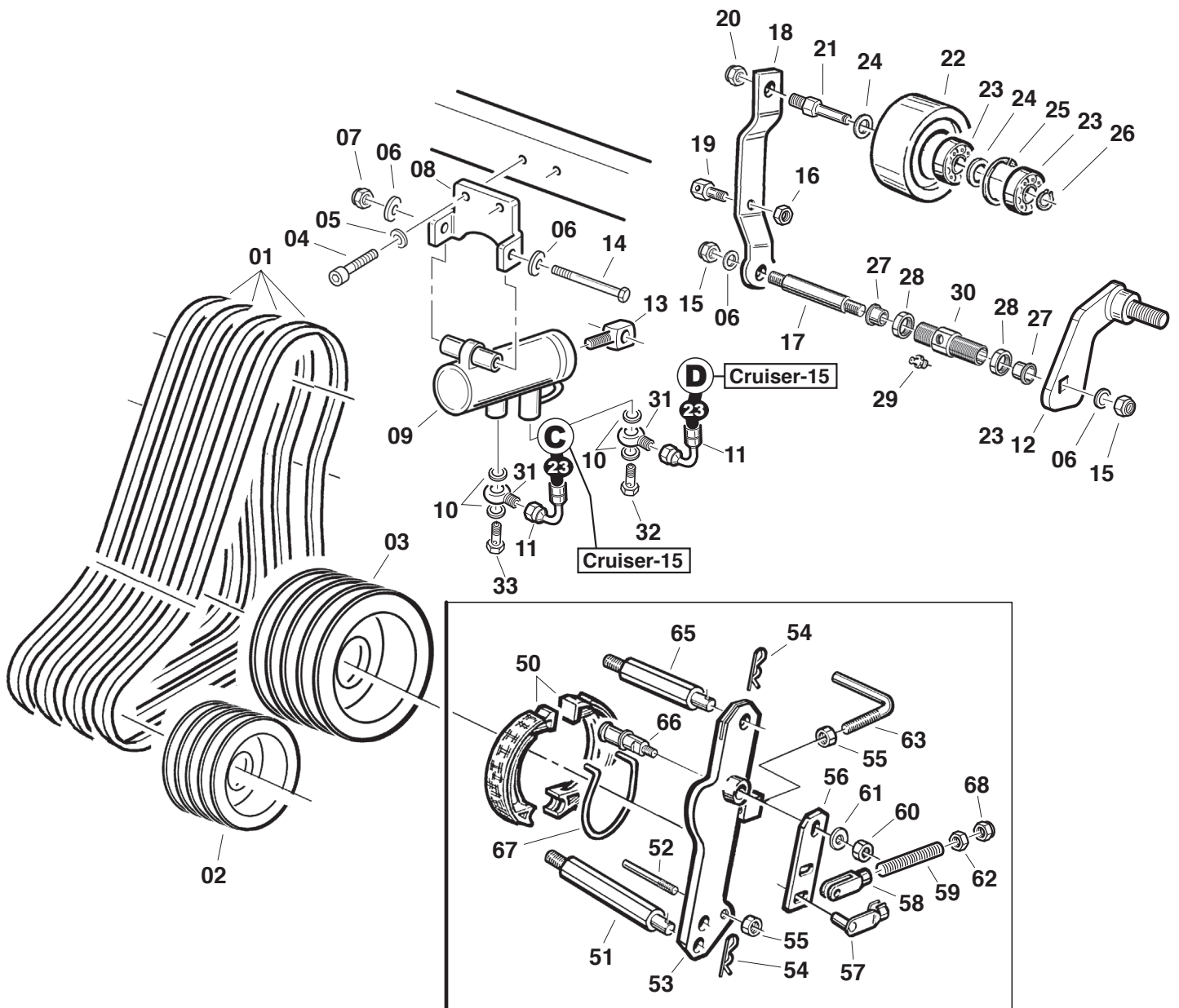

REF.	LEG.	CODE	Q.TY
1		00.17.01.1450	4
2		00.61.00.0450	1
3		00.61.00.0390	1
4		00.90.07.0141	2
5		00.68.12.0010	2
6		00.68.01.0040	4
7		00.26.05.0070	1
8		01.60.00.0164	1
9		00.58.00.0238	1
10		00.41.00.0873	4
11		00.41.00.3872	2
12		01.50.00.0029	1
13		01.40.20.0075	1
14		00.92.06.0220	1
15		00.26.05.0070	2
16		00.26.05.0060	1
17		01.40.00.0261	1

REF.	LEG.	CODE	Q.TY
18		01.50.00.5790	1
19		01.40.00.1195	1
20		00.26.04.0080	1
21		01.40.00.2760	1
22		00.61.00.0381	1
23		00.22.15.4201	2
24		01.40.00.1090	1
25		00.03.01.0042	1
26		00.03.00.0110	1
27		01.20.00.0050	2
28		01.40.00.2090	2
29		00.42.00.0010	1
30		01.40.00.1790	1
31		00.41.00.0243	2
32		00.41.00.0134	1
33		00.41.00.0121	1
50		00.34.01.0010	2

REF.	LEG.	CODE	Q.TY
51		01.40.00.2240	1
52		01.40.00.2280	1
53		01.50.00.2710	1
54		00.18.00.1011	2
55		00.26.02.0060	2
56		01.50.00.2820	1
57		00.33.01.0021	1
58		00.33.01.0020	1
59		00.96.04.0115	1
60		00.26.05.0040	1
61		00.68.02.0030	1
62		00.26.02.0040	1
63		01.50.00.2040	1
65		01.40.00.2241	1
66		00.34.01.0013	1
67		00.34.01.0011	1
68		00.26.04.0040	1

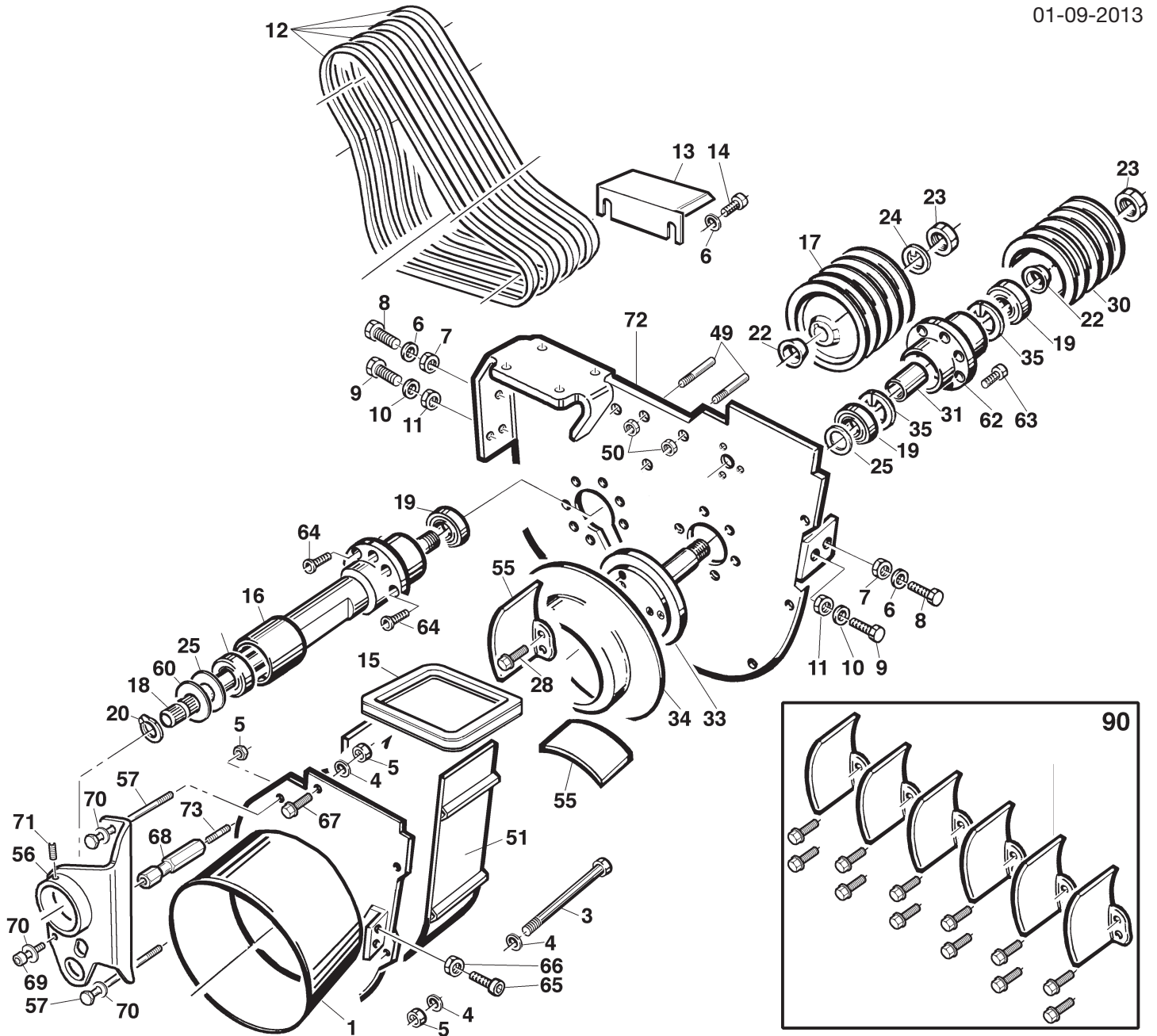

REF.	LEG.	CODE	Q.TY
01		01.50.00.4820	1
03		00.92.05.0280	6
04		00.68.01.0030	16
05		00.26.05.0060	9
06		00.68.01.0040	8
07		00.26.02.0080	2
08		00.92.06.1120	2
09		00.92.07.0110	4
10		00.68.01.0050	6
11		00.26.04.0080	2
12		00.17.01.1450	4
13		01.50.00.3740	1
14		00.92.06.1020	2
15		01.90.00.0550	1
16		01.40.00.1970	1
17		00.61.00.0390	1
18		01.40.00.0021	1

REF.	LEG.	CODE	Q.TY
19		00.22.20.5202	4
20		00.03.10.0020	1
22		01.40.00.0710	2
23		00.26.03.1130	2
24		01.40.00.1050	1
25		01.40.00.2030	2
28		00.90.07.1060	12
30		00.61.00.0450	1
31		01.40.00.0590	1
33		01.40.00.2000	1
34		01.50.00.4840	1
35		00.03.01.0052	2
49		01.40.00.2280	2
50		00.26.02.0060	2
51		01.50.00.4830	1
55		01.50.00.4851	6
56		01.50.00.7380	1

REF.	LEG.	CODE	Q.TY
57		00.92.05.0290	2
60		00.48.01.0021	1
62		01.40.00.2011	1
63		00.90.07.0080	6
64		00.90.07.0060	7
65		00.90.07.0100	2
66		00.26.05.0070	2
67		00.92.05.0120	1
68		01.40.00.4740	1
69		00.90.06.0081	1
70		00.68.12.0008	3
71		00.96.05.0010	1
72		01.50.01.4810	1
73		00.60.02.0040	1
90		01.90.00.2060	1



Gianni Ferrari

Cruiser-05

T2-T2T-T4-T4T

1152084

01-09-2013

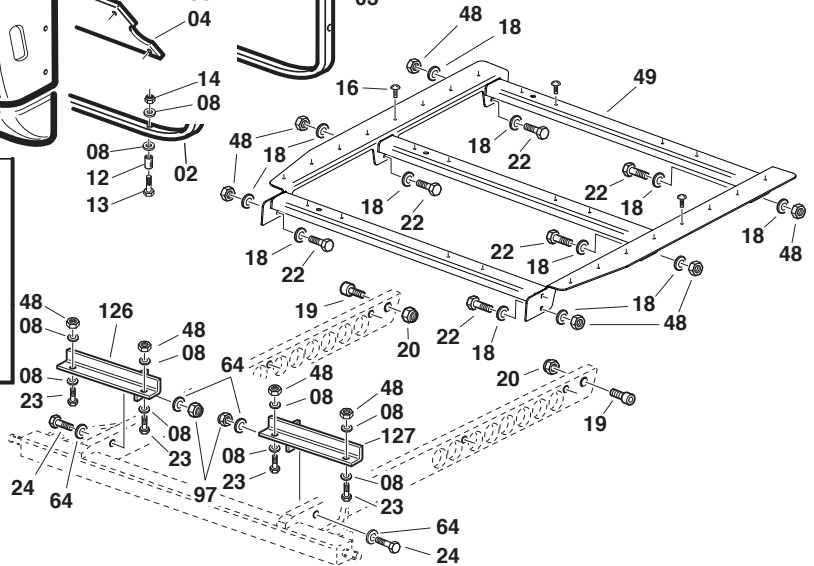
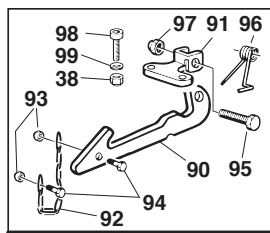
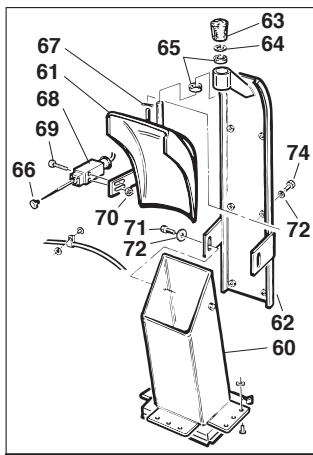
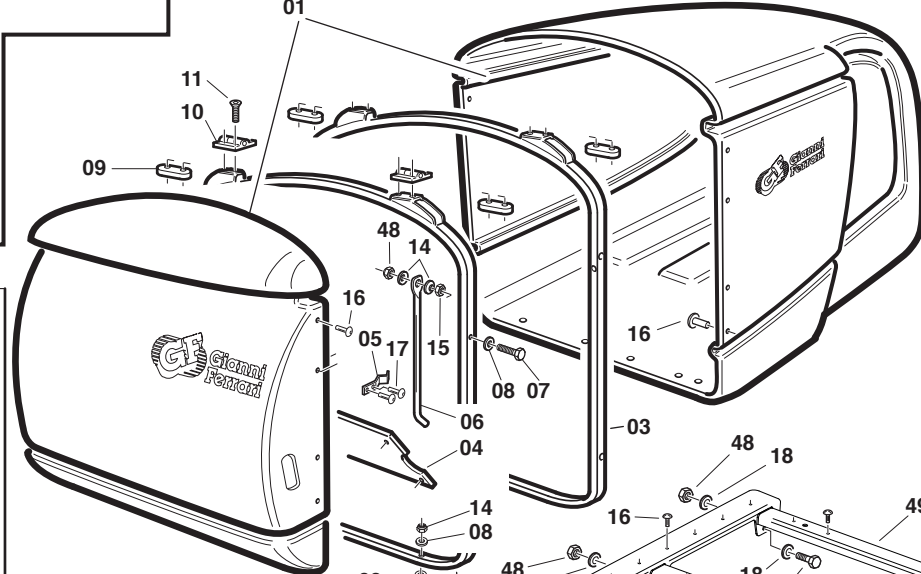
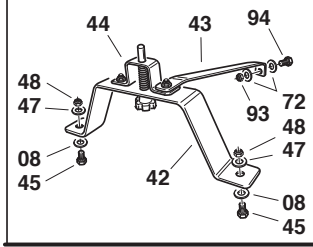
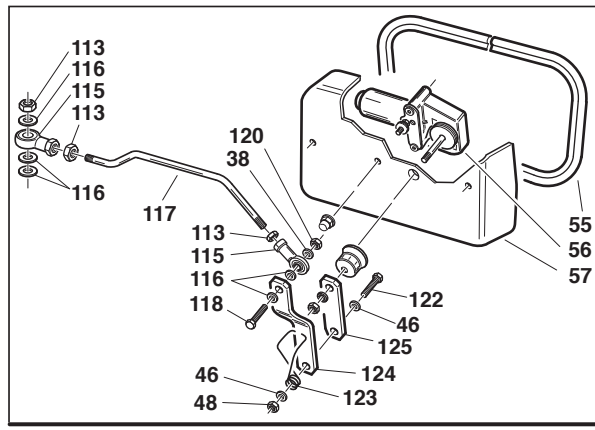
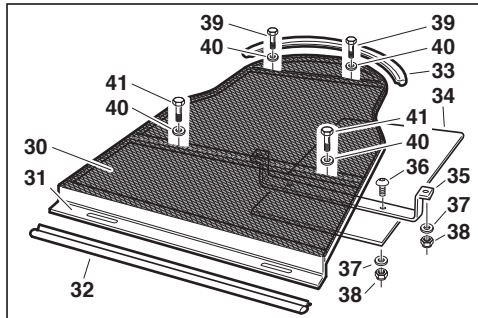

REF.	LEG.	CODE	Q.TY
1		01.30.00.0325	1
2		01.50.00.8985	1
3		01.50.00.8984	1
4		01.60.00.0934	1
5		00.47.00.0420	1
6		01.50.00.8970	1
7		00.92.05.0160	1
8		00.68.01.0030	16
9		01.50.01.3400	4
10		00.99.00.0250	2
11		00.95.05.0060	8
12		01.40.00.0491	2
13		00.90.06.0150	2
14		00.48.00.0079	2
15		00.26.02.0060	1
16		00.66.06.0071	140
17		00.66.06.0091	2
18		00.68.02.0051	12
19		00.90.07.0110	2
20		00.26.05.0070	2
22		00.92.05.1160	6
23		00.92.05.0131	4
24		00.92.06.0110	2
25		00.41.00.3841	1
26		00.45.00.0006	2
30		01.60.00.0663	1
31		01.50.00.9038	1
32		00.11.01.2000	2m
33		00.11.01.2000	0.6m
34		01.50.00.4100	1
35		01.60.00.0845	1

REF.	LEG.	CODE	Q.TY
42		01.50.01.3951	1
43		01.60.00.0933	1
44		01.50.01.3970	1
47		00.68.02.0050	2
48		00.26.04.0060	14
49		01.50.00.5243	1
55		00.11.01.2000	1
56		00.54.00.2040	1
57		01.30.00.9038	1
60		01.50.01.3930	1
61		01.50.00.1395	1
62		01.50.01.4010	1
63		00.07.03.0120	1
64		00.68.02.0070	5
65		00.22.00.0111	2
66		00.45.01.0040	1
67		00.18.04.0021	1
68		00.40.00.0042	1
69		00.91.04.0110	2
70		00.26.04.0020	2
71		00.92.03.1030	2
72		00.68.02.0030	10
74		00.91.03.0050	6
90		01.50.00.6481	1

REF.	LEG.	CODE	Q.TY
91		01.50.00.6482	1
92		01.50.00.0837	1
93		00.26.04.0040	3
94		00.92.03.1070	3
95		00.92.06.0110	1
96		00.47.00.0190	1
97		00.26.04.0070	1
98		00.92.03.1120	1
99		00.68.01.0020	1
110		01.30.00.0531	1
112		00.54.00.2040	1
113		00.26.02.0040	3
115		00.78.01.0010	2
116		00.68.01.0020	5
117		01.50.00.8800	1
118		00.92.03.1110	1
120		00.26.04.0040	1
122		00.92.05.0110	1
123		00.47.00.0410	1
124		01.50.00.8780	1
125		01.50.00.8790	1
126		01.50.00.5242	1
127		01.50.00.0168	1



**Gianni
Ferrari**

1k52069

Cruiser-06

T4-T4T

01-09-2013

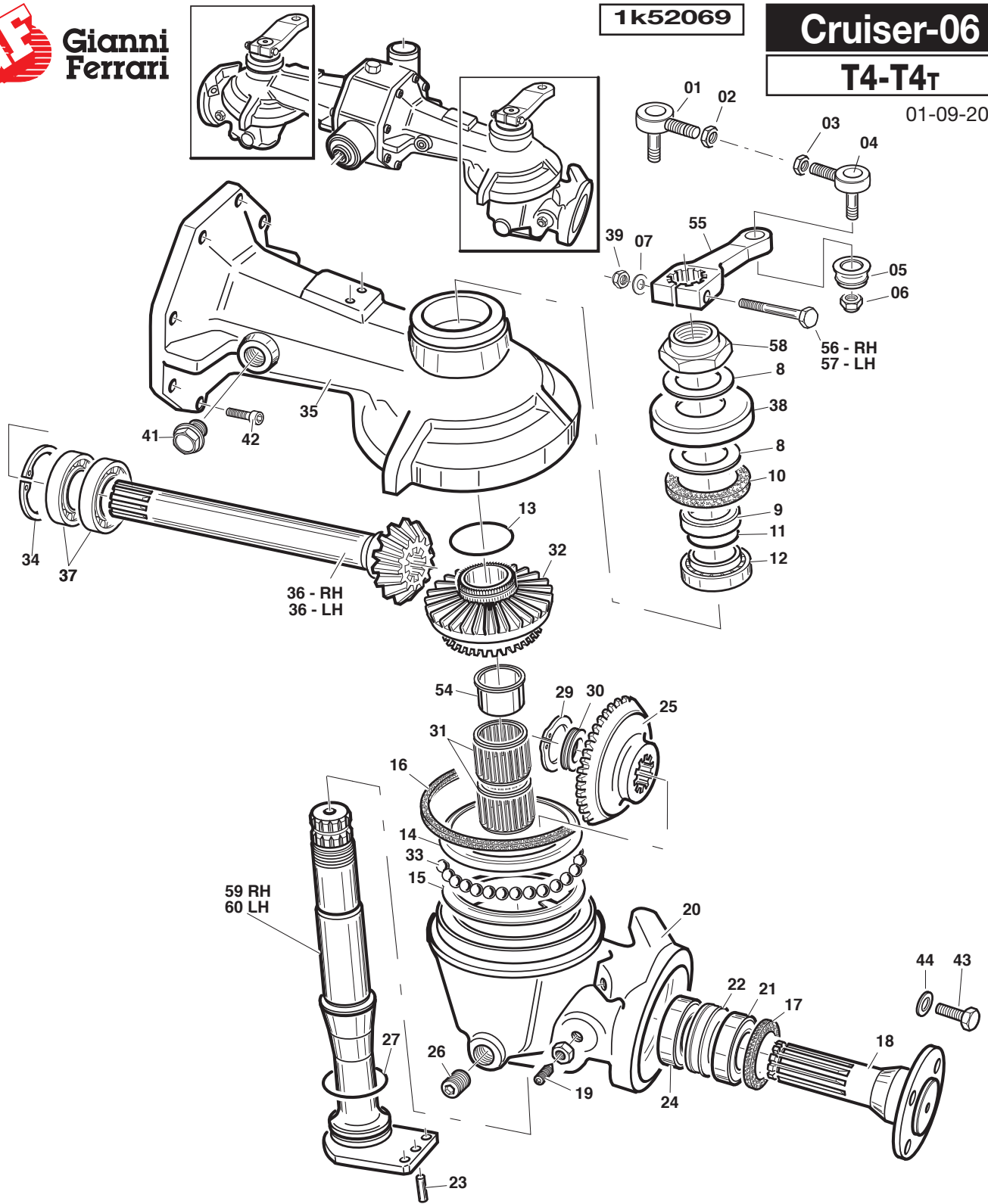

REF.	LEG.	CODE	Q.TY
01		00.78.10.0030	1
02		00.26.03.2111	1
03		00.26.03.2110	1
04		00.78.10.0040	1
05		00.07.01.0121	2
06		00.26.05.1090	2
07		00.68.01.0040	2
08		00.48.00.0230	2
09		01.40.00.1730	1
10		00.05.40.0055	1
11		00.06.07.0298	1
12		00.21.30.5501	1
13		00.03.20.0055	1
14		01.50.00.6020	1
15		01.50.00.6030	1
16		00.05.00.0157	1
17		00.05.45.0072	1

REF.	LEG.	CODE	Q.TY
18		01.40.00.1650	1
19		00.96.06.2100	2
20		01.01.00.0140	1
21		00.22.35.7201	1
22		01.40.00.1720	1
23		00.83.16.1020	1
24		00.22.30.7201	1
25		01.40.00.1610	1
26		00.85.02.0072	1
27		00.06.07.0360	1
29		00.03.00.0320	1
30		01.40.00.1780	1
31		00.35.32.4025	2
32		01.40.00.1620	1
33		00.76.00.0111	35
34		00.03.11.0052	1
35		01.01.00.0162	1

REF.	LEG.	CODE	Q.TY
36	RH	01.40.00.1635	1
36	LH	01.40.00.1630	1
37		00.22.25.5201	2
38		01.50.00.4590	1
39		00.26.04.1070	1
41		00.85.03.0002	1
42		00.90.06.0110	8
43		00.92.07.3051	4
44		00.68.05.0010	4
54		01.20.00.0110	1
55		01.01.00.0330	1
56	RH	00.92.06.2171	1
57	LH	00.92.06.2151	1
58		01.40.00.3790	1
59	RH	01.50.01.0252	1
60	LH	01.50.01.0262	1

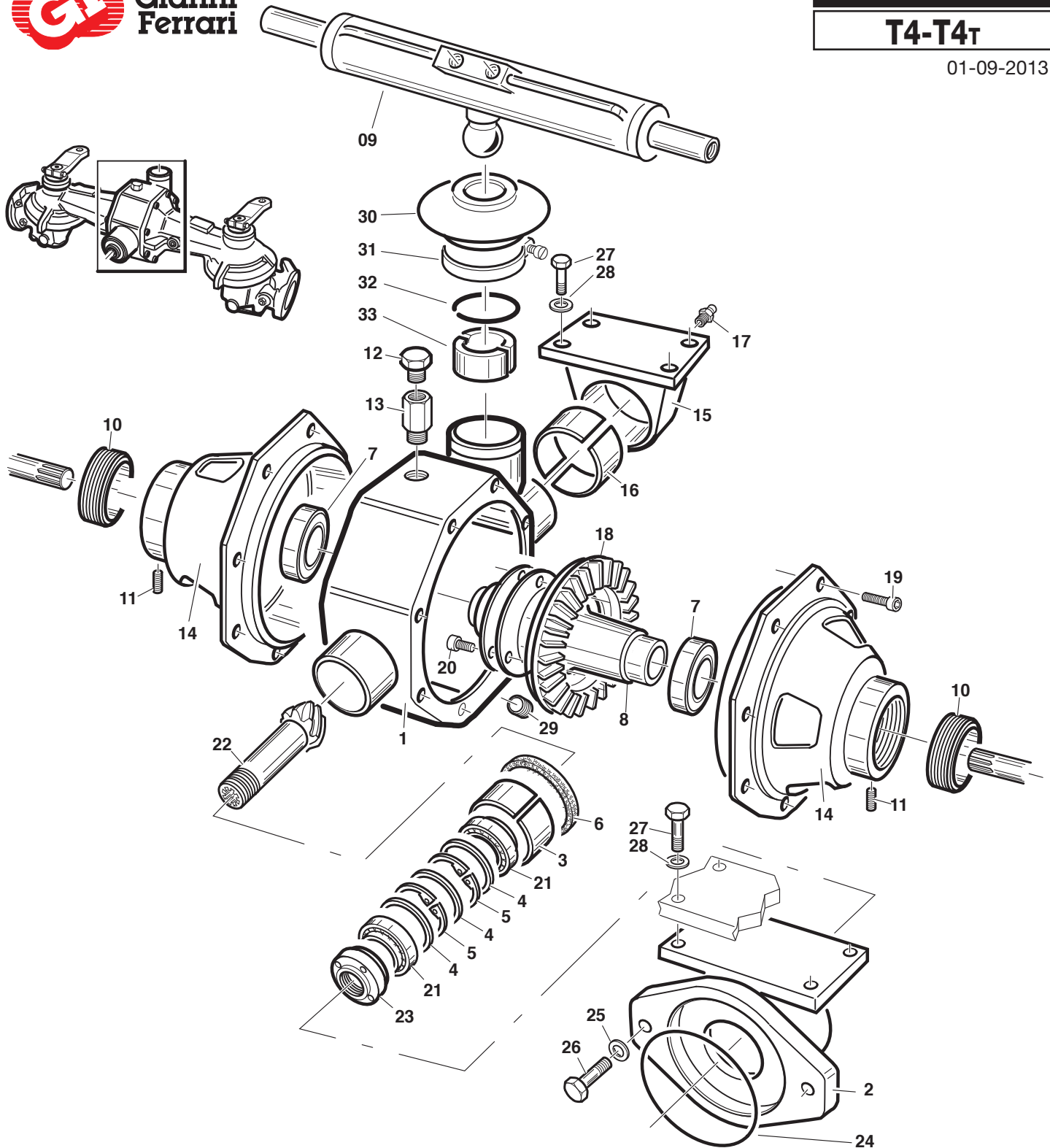

REF.	LEG.	CODE	Q.TY
1		01.01.00.0120	1
2		01.50.00.4580	1
3		00.10.70.0040	1
4		01.40.00.1740	3
5		00.03.01.0055	2
6		00.05.70.0085	1
7		00.21.40.6801	2
8		01.90.00.0880	1
9		00.58.00.0078	1
10		01.40.00.1770	2
11		00.96.04.2009	2

REF.	LEG.	CODE	Q.TY
12		00.85.03.0013	1
13		00.41.00.0935	1
14		01.01.00.0130	2
15		01.50.00.4570	1
16		00.10.45.0030	1
17		00.42.00.0010	1
18		01.40.00.1580	1
19		00.90.06.0110	16
20		00.90.06.0080	6
21		00.21.30.5501	2
22		01.40.00.1590	1

REF.	LEG.	CODE	Q.TY
23		01.40.00.1750	1
24		00.06.07.1013	1
25		00.68.01.0050	2
26		00.92.07.3090	2
27		00.92.06.1080	8
28		00.68.01.0040	8
29		00.85.02.0072	1
30		00.07.01.0120	1
31		00.29.03.0010	1
32		01.20.00.0101	1
33		01.20.00.0100	1



**Gianni
Ferrari**

1152084

Cruiser-08

T2-T2T

01-09-2013

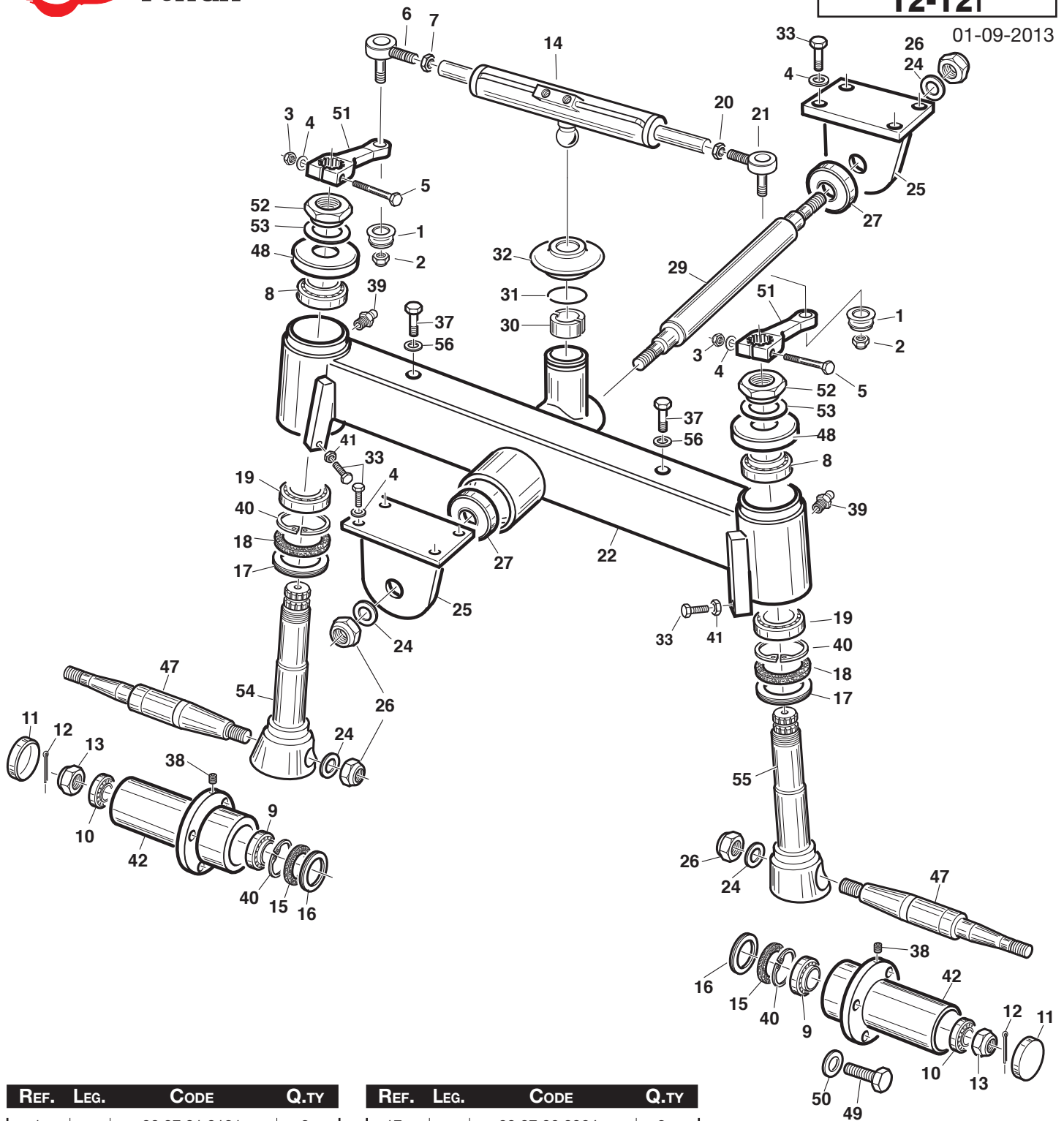

REF.	LEG.	CODE	Q.TY
1		00.07.01.0121	2
2		00.26.05.1090	2
3		00.26.04.1070	2
4		00.68.01.0040	10
5		00.92.06.2151	2
6		00.78.10.0030	1
7		00.26.03.2111	1
8		00.21.30.5501	2
9		00.21.30.6201	2
10		00.21.20.4701	2
11		00.07.06.0047	2
12		00.18.04.0054	2
13		00.26.07.1110	2
14		00.58.00.0078	1
15		00.05.40.0062	2
16		00.07.06.0063	2

REF.	LEG.	CODE	Q.TY
17		00.07.06.0064	2
18		00.05.45.0062	2
19		00.21.35.6201	2
20		00.26.03.2110	1
21		00.78.10.0040	1
22		01.50.00.6293	1
24		00.68.01.0090	4
25		01.50.00.6290	2
26		00.26.04.1120	4
27		00.22.00.0270	2
29		01.50.00.6300	1
30		01.20.00.0100	1
31		01.20.00.0101	1
32		00.07.01.0120	1
33		00.92.06.1090	10
37		00.92.05.1100	2

REF.	LEG.	CODE	Q.TY
38		00.96.04.0009	2
39		00.42.00.0020	3
40		00.03.01.0062	2
41		00.26.02.0080	2
42		01.40.00.2381	2
47		01.40.00.2373	2
48		01.50.00.4590	2
49		00.92.07.3051	8
50		00.68.05.0010	8
51		01.01.00.0330	2
52		01.40.00.3790	2
53		00.48.01.0027	2
54	RH	01.40.00.2376	1
55	LH	01.40.00.2377	1
56		00.68.08.0170	2

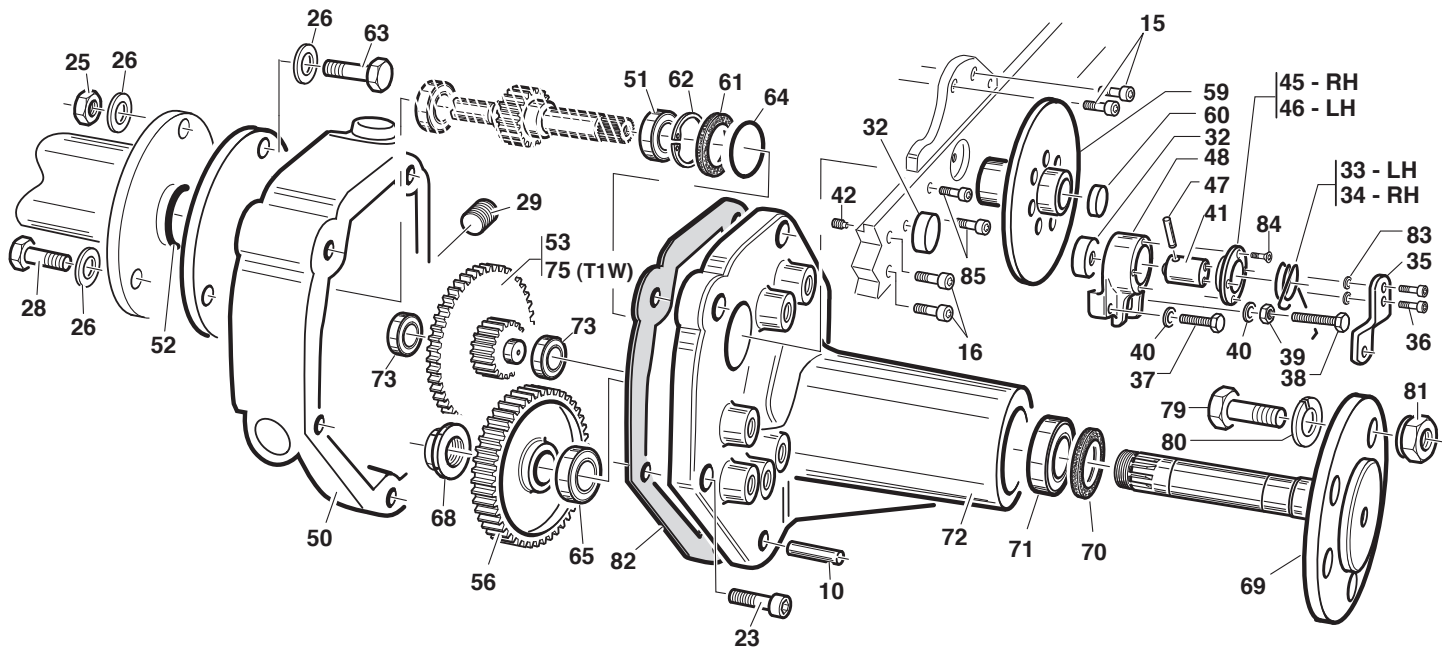
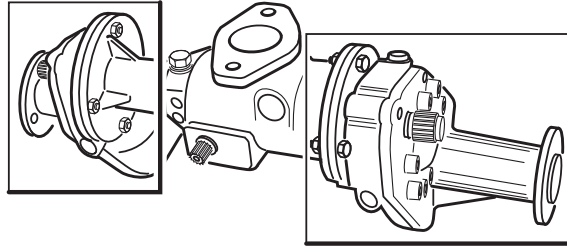

REF.	LEG.	CODE	Q.TY
10		00.83.14.2024	2
15		00.90.07.0082	2
16		00.90.07.0101	2
23		00.90.06.0081	12
25		00.26.02.0080	2
26		00.68.01.0040	4
28		00.90.07.0090	2
29		00.85.00.0090	2
32		00.34.01.0034	2
33	LH	00.47.00.0280	1
34	RH	00.47.00.0290	1
35		01.50.00.5540	1
36		00.90.04.0070	2
37		00.92.05.0110	1
38		00.92.05.0170	1
39		00.26.02.0060	1
40		00.68.01.0030	1

REF.	LEG.	CODE	Q.TY
41		00.34.01.0035	1
42		00.96.06.0040	1
43		00.92.07.3051	4
45	RH	00.34.01.0112	1
46	LH	00.34.01.0113	1
47		00.83.14.3040	2
48		00.34.01.0110	2
50		01.01.00.0230	1
51		00.22.25.5201	1
52		00.06.07.0521	1
53		01.40.00.1901	1
56		01.40.00.1911	1
59		01.40.00.2101	1
60		00.07.06.0032	1
61		00.05.00.0010	1
62		00.03.01.0052	1
63		00.92.06.0120	2

REF.	LEG.	CODE	Q.TY
64		00.06.07.0202	1
65		00.21.30.6201	1
68		01.40.00.2530	1
69		01.40.00.4390	1
70		00.05.45.0062	1
71		00.21.35.6201	1
72		01.01.00.0260	1
73		00.20.17.4702	2
75	T1W	01.40.00.1902	1
79		00.92.08.3081	5
80		00.68.04.0140	5
81		00.26.08.0020	5
82		00.07.01.0101	1
83		00.68.01.0020	2
84		00.95.03.0040	4
85		00.90.07.0121	2

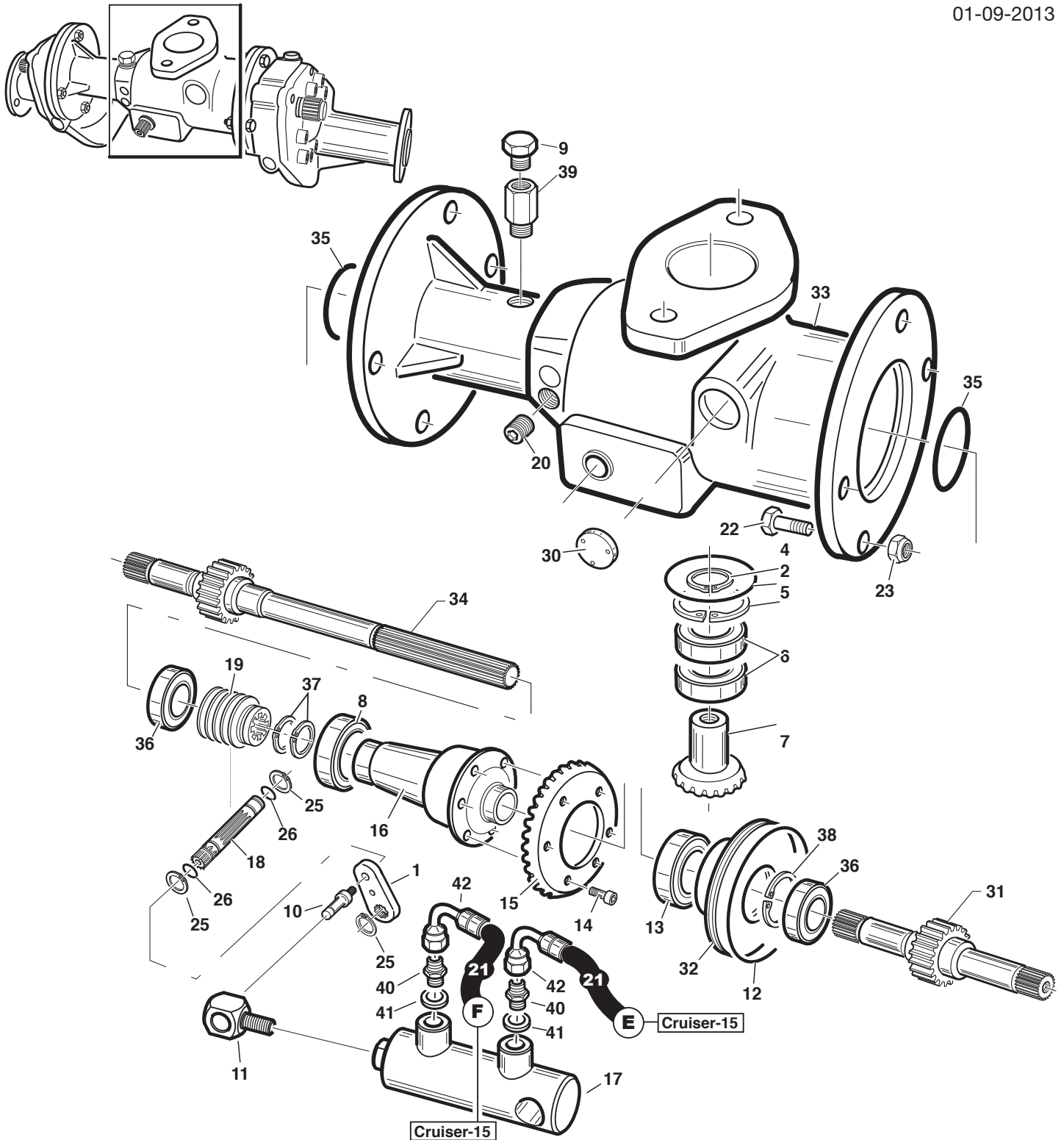

REF.	LEG.	CODE	Q.TY	REF.	LEG.	CODE	Q.TY	REF.	LEG.	CODE	Q.TY
1		01.60.00.0641	1	14		00.90.06.0050	6	31		01.40.00.1671	1
2		00.06.07.0822	1	15		01.40.00.1560	1	32		01.01.00.0111	1
4		00.03.00.0310	1	16		01.90.00.0730	1	33		01.01.00.0240	1
5		00.03.01.0072	1	17		00.58.20.0015	1	34		01.40.00.1681	1
6		00.22.35.7201	2	18		01.40.00.1760	1	35		00.06.07.0521	1
7		01.40.00.1570	1	19		01.40.00.1810	1	36		00.22.25.5201	2
8		00.22.45.7501	1	20		00.85.02.0072	1	37		00.03.00.0310	2
9		00.85.03.0013	1	22		00.92.06.1090	8	38		00.03.01.0052	1
10		01.40.00.0231	1	23		00.26.02.0080	8	39		00.41.00.0933	1
11		01.40.20.0075	1	25		00.03.00.0160	3	40		00.41.00.0780	2
12		00.06.07.1013	1	26		00.06.07.0150	2	41		00.41.00.0060	2
13		00.22.40.6801	1	30		00.07.06.0032	1	42		00.41.00.3870	2



**Gianni
Ferrari**

1152084

Cruiser-11

T2-T2T-T4-T4T

01-09-2013

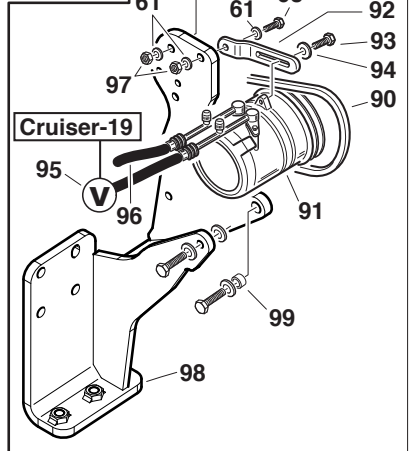
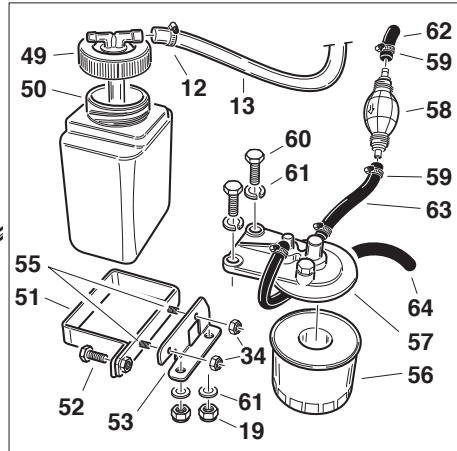
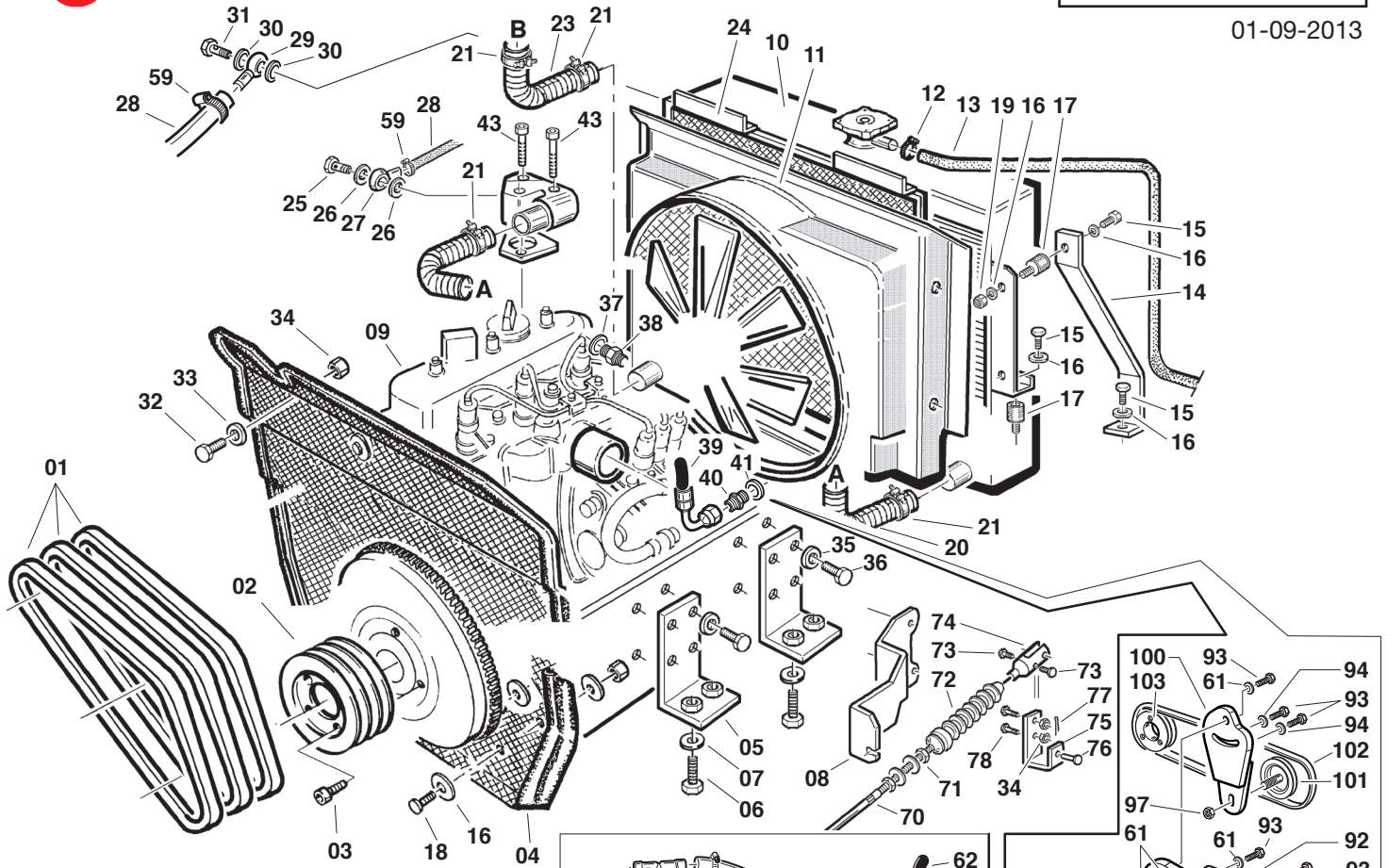

REF.	LEG.	CODE	Q.TY
1		00.17.01.0040	3
2		00.61.00.0500	1
3		00.90.07.1160	3
4		01.50.00.5013	1
5		01.50.00.2780	4
6		00.92.06.1080	8
7		00.68.02.0070	8
8		01.50.01.4730	1
9	T2-T4	00.54.01.0040	1
9	T2T-T4T	00.54.01.0041	1
10		00.54.10.0039	1
11		00.54.10.0045	1
12		00.29.10.0030	2
13		00.89.10.3000	1,5 m
14		01.50.00.6510	2
15		00.92.05.1040	6
16		00.68.02.0050	17
17		00.74.03.0070	4
18		00.92.05.1070	10
19		00.26.04.0060	4
20		00.07.07.0315	1
21		00.29.02.1039	4
23		00.07.07.0140	1
24		00.54.10.0046	1
25		00.41.00.0204	1
26		00.41.00.0211	2
27		00.41.00.0191	1
28		00.89.01.0000	0,6
29		00.41.00.0190	1
30		00.41.00.0210	2
31		00.41.00.0200	1
32		00.92.03.1070	1
33		00.68.01.0020	1
34		00.26.04.0040	5
35		00.68.12.0010	12
36		00.92.06.3051	16
37		00.41.00.0070	1
38		00.41.00.0784	1

REF.	LEG.	CODE	Q.TY
39		00.41.00.3893	1
40		00.41.00.0113	1
41		00.41.00.0071	1
43		00.92.05.1110	2
49		00.75.00.0043	1
50		00.75.00.0042	1
51		01.50.20.0485	1
52		00.92.03.1040	1
53		01.50.00.5286	1
55		00.95.04.0060	2
56		00.32.03.0040	1
57		00.55.01.0390	1
58		00.99.00.0320	1
59		00.29.02.0016	4
60		00.92.05.0100	2
61		00.68.01.0030	6
62		00.89.02.0000	0,95m
63		00.89.02.0000	1m
64		00.89.02.0000	1,32m
70		00.25.01.0170	1
71		01.40.00.0500	1

REF.	LEG.	CODE	Q.TY
72		00.47.20.0010	1
73		00.92.02.1020	2
74		01.40.00.4930	1
75		01.50.01.4740	1
76		00.33.02.0022	1
77		00.18.04.0021	1
78		00.92.03.1040	2
90		00.17.01.0060	1
91		00.55.05.0015	1
92		01.60.00.0335	1
93		00.92.05.1100	7
94		00.68.08.0170	3
95		00.99.00.0701	1
96		00.99.00.0700	1
97		00.26.05.0060	3
98		01.50.00.0144	1
99		01.40.00.0037	1
100		01.50.00.0143	1
101		00.55.01.0710	1
102		00.17.04.0220	1
103		01.40.00.0034	1

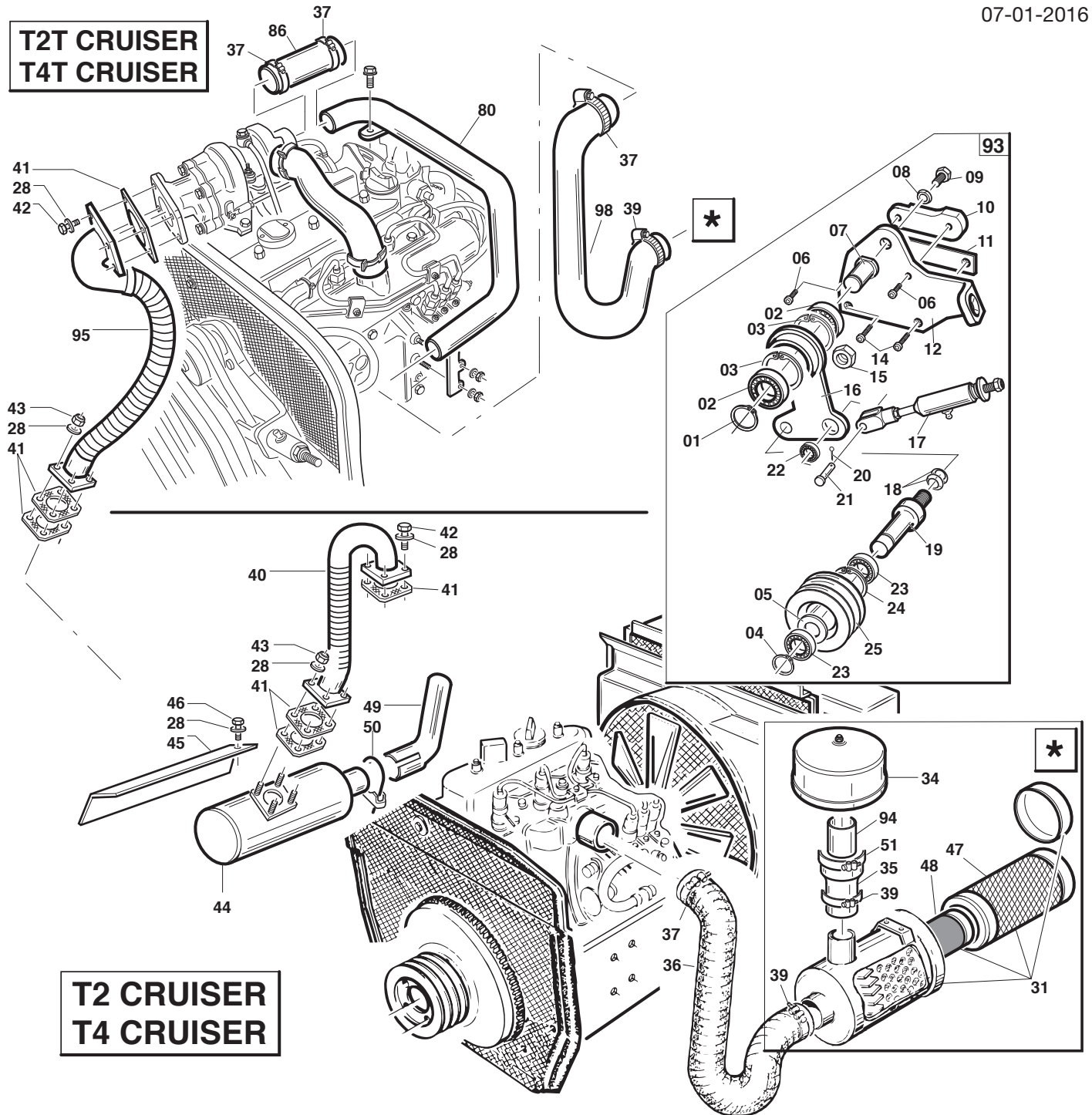
**T2T CRUISER
T4T CRUISER**

**T2 CRUISER
T4 CRUISER**

REF.	LEG.	CODE	Q.TY
1		00.03.10.0020	1
2		00.22.00.0230	2
3		00.03.01.0047	2
4		00.03.10.0015	1
5		01.40.00.1090	1
6		00.92.05.0110	2
7		01.40.00.4020	1
8		00.68.05.0010	1
9		00.92.07.1070	1
10		01.50.01.1634	1
11		01.50.01.1633	2
12		01.50.01.1631	1
14		00.90.07.1150	2
15		00.26.04.0080	1
16		01.50.01.1620	1
17		01.90.00.2185	1
18		00.48.01.0160	2

REF.	LEG.	CODE	Q.TY
19		01.40.00.2760	1
20		00.18.04.0052	1
21		00.33.03.0022	1
22		00.22.00.0111	1
23		00.22.15.4201	2
24		00.03.01.0042	1
25		00.61.00.0371	1
28		00.68.01.0030	19
31		00.32.06.0010	1
33		00.32.03.0060	1
34		00.32.03.0170	1
35		00.07.07.0150	1
36		00.07.07.0130	1
37		00.29.02.0060	4
39		00.29.02.0070	3
40		01.50.00.5180	1
41		00.55.01.0210	7

REF.	LEG.	CODE	Q.TY
42		00.92.05.1070	8
43		00.26.01.0060	8
44		00.46.00.0040	1
45		01.50.00.4010	1
46		00.92.05.1010	2
47		00.32.06.0011	1
48		00.32.06.0012	1
49		00.46.00.0012	1
50		00.52.01.0045	1
51		00.29.02.0080	3
80		01.50.01.3260	1
86		00.89.04.0035	0.30 ML
93		01.90.00.2330	
94		00.10.60.0060	1
95		01.50.01.2730	1
98		00.07.07.0200	1



Gianni Ferrari

1152084

Cruiser-13
T2-T2T-T4-T4T

01-09-2013

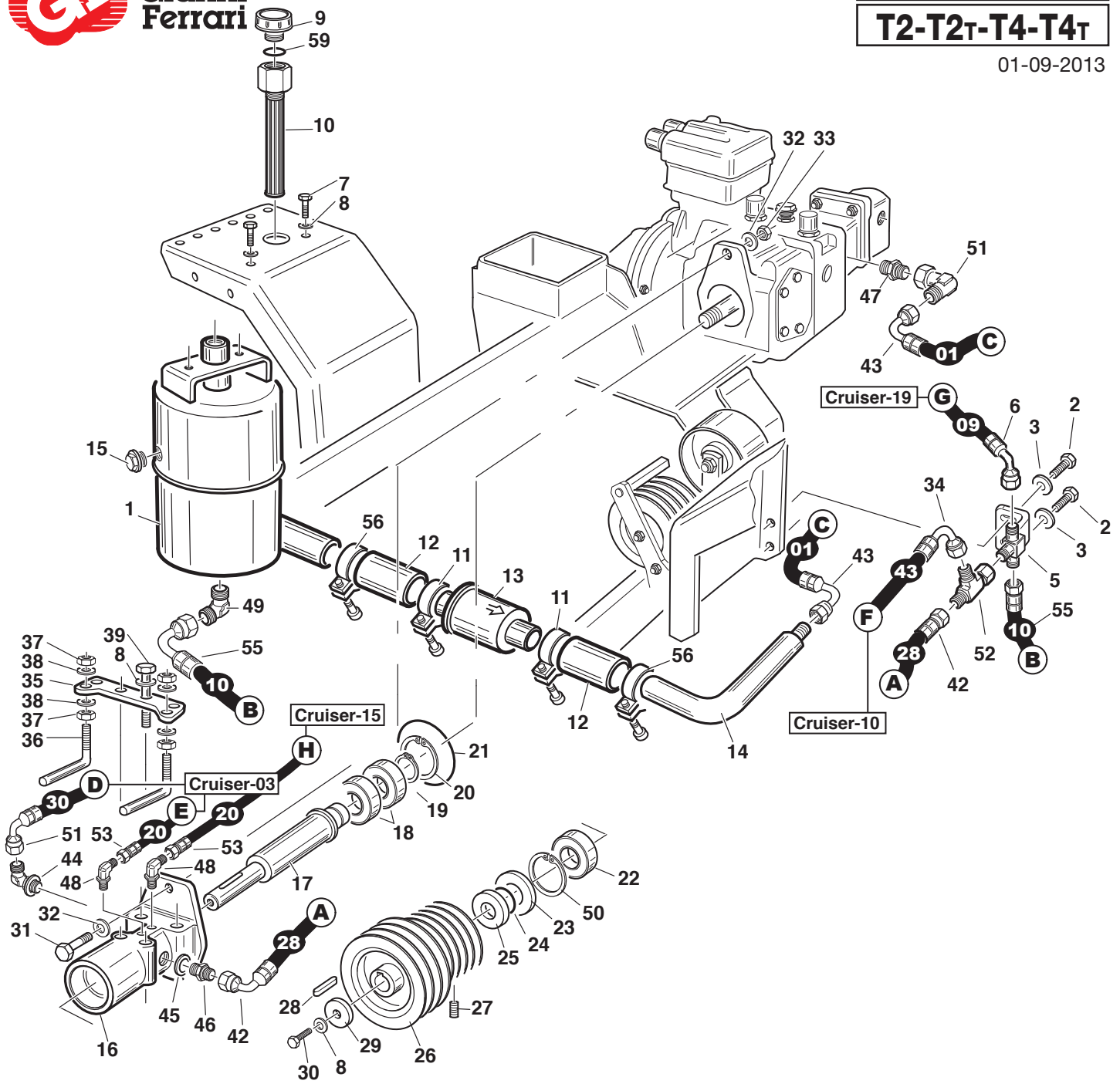

REF.	LEG.	CODE	Q.TY
1		00.75.00.0071	1
2		00.92.05.1040	2
3		00.68.01.0030	2
5		01.50.00.0027	1
6		00.41.00.3858	1
7		00.92.06.1040	2
8		00.68.01.0040	7
9		00.85.03.0014	1
10		00.32.03.0070	1
11		00.29.02.0050	2
12		00.89.04.0038	0.2
13		00.32.03.0080	1
14		01.50.00.5431	1
15		00.85.03.0004	1
16		01.01.00.0350	1
17		01.40.00.1840	1
18		00.22.00.0280	1
19		00.03.00.0260	1
20		00.03.01.0055	1
21		00.06.07.1013	1
22		00.22.25.6202	1

REF.	LEG.	CODE	Q.TY
23		00.05.40.2062	1
24		00.06.07.0239	1
25		01.40.00.2250	1
26		00.61.00.0510	1
27		00.96.05.0030	2
28		00.43.00.0110	1
29		00.68.08.0303	1
30		00.92.06.1060	1
31		00.92.07.0130	2
32		00.68.01.0050	4
33		00.26.04.0080	2
34		00.41.00.3897	1
35		01.50.00.2030	1
36		01.50.00.2040	2
37		00.26.02.0060	4
38		00.68.01.0030	4
39		00.92.06.0210	4
40	T4	00.41.00.1051	1
41	T4	00.41.00.3070	1
42		00.41.00.3876	1
43		00.41.00.3850	1

REF.	LEG.	CODE	Q.TY
44		00.41.00.0876	1
45		00.41.00.0071	1
46		00.41.00.0113	1
47		00.41.00.0826	1
48		00.41.00.0873	2
49		00.41.00.0878	1
50		00.03.01.0062	1
51		00.41.00.3880	1
52		00.41.00.0882	1
53		00.41.00.3869	2
55		00.41.00.3859	1
56		00.29.02.1051	2
57	T4	00.41.00.0733	1
59		00.06.07.0314	1
61		00.41.00.0293	1
62		00.41.00.0450	1
63		00.41.00.2921	1
66		00.41.00.0060	2
67		00.41.00.3070	1
68		00.41.00.0738	1



Gianni Ferrari

1152084

Cruiser-14

T4-T4T

01-09-2013

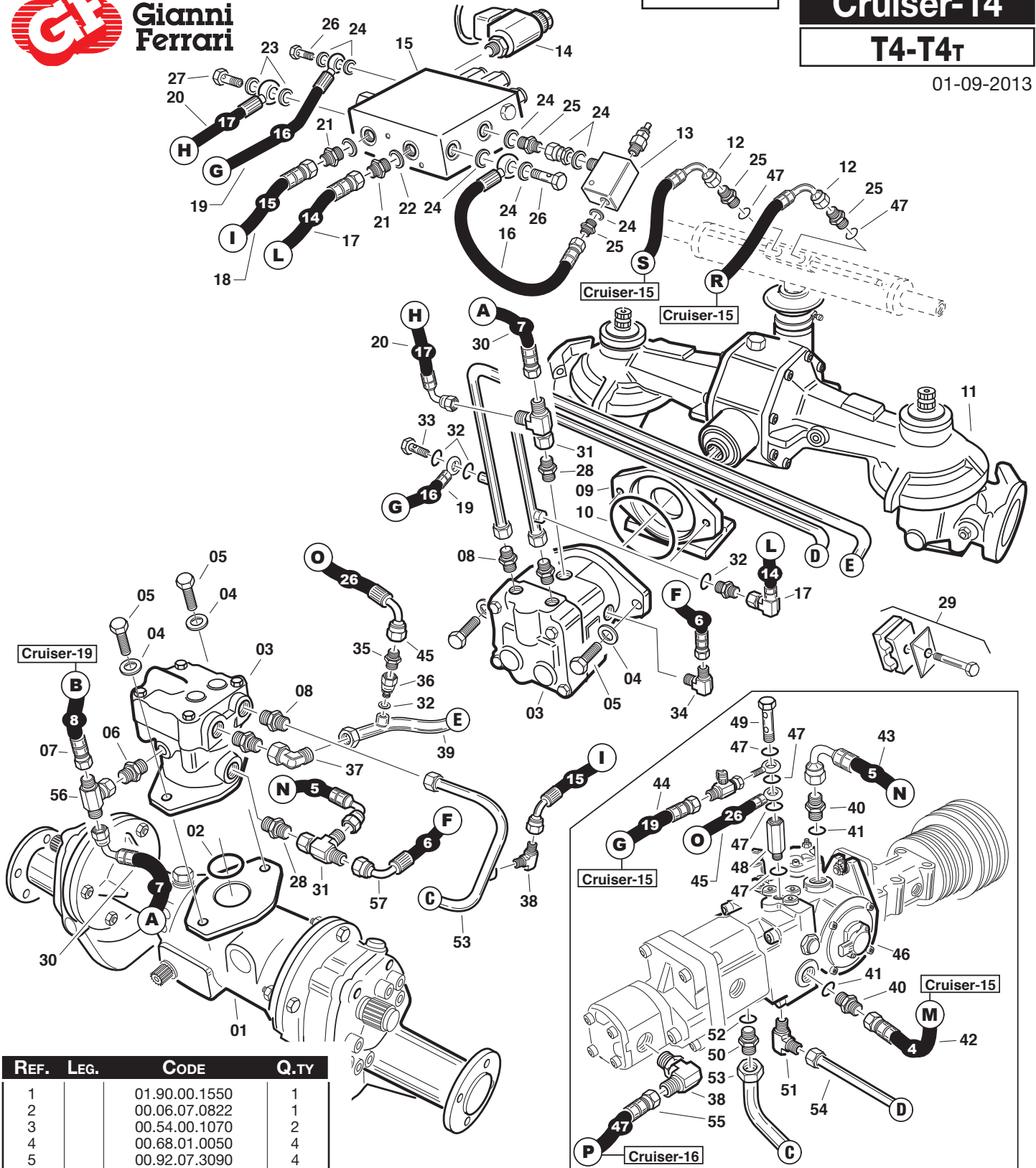

REF.	LEG.	CODE	Q.TY
1		01.90.00.1550	1
2		00.06.07.0822	1
3		00.54.00.1070	2
4		00.68.01.0050	4
5		00.92.07.3090	4
6		00.41.00.0819	1
7		00.41.00.3857	1
8		00.41.00.1275	4
9		01.50.00.4580	1
10		00.06.07.1013	1
11		01.90.00.0925	1
12		00.41.00.3867	2
13		00.41.00.1501	1
14		00.41.00.3021	1
15		00.41.00.3240	1
16		00.41.20.0040	1
17		00.41.00.3863	1
18		00.41.00.3864	1
19		00.41.00.3865	1
20		00.41.00.3866	1
21		00.41.00.0784	2
22		00.41.00.1289	2
23		00.41.00.0071	2
24		00.41.00.1292	7

REF.	LEG.	CODE	Q.TY
25		00.41.00.0450	4
26		00.41.00.0120	2
27		00.41.00.0125	1
28		00.41.00.0818	2
29		00.41.00.0442	2
30		00.41.00.3854	1
31		00.41.00.0882	2
32		00.41.00.1290	4
33		00.41.00.0250	1
34		00.41.00.2205	1
35		00.41.00.0114	1
36		00.41.00.2212	1
37		00.41.00.0945	1
38		00.41.00.0875	2
39		00.41.00.3861	1
40		00.41.00.0789	2
41		00.41.00.0073	2

REF.	LEG.	CODE	Q.TY
42		00.41.00.3851	1
43		00.41.00.3852	1
44		00.41.00.3869	1
45		00.41.00.3875	1
46		00.41.00.0771	1
47		00.41.00.0060	6
48		00.41.00.0938	1
49		00.41.00.0124	1
50		00.41.00.0823	1
51		00.41.00.2871	1
52		00.41.00.1293	1
53		00.41.00.3860	1
54		00.41.00.3862	1
55		00.41.00.0876	1
56		00.41.00.0732	1
57		00.41.00.3855	1

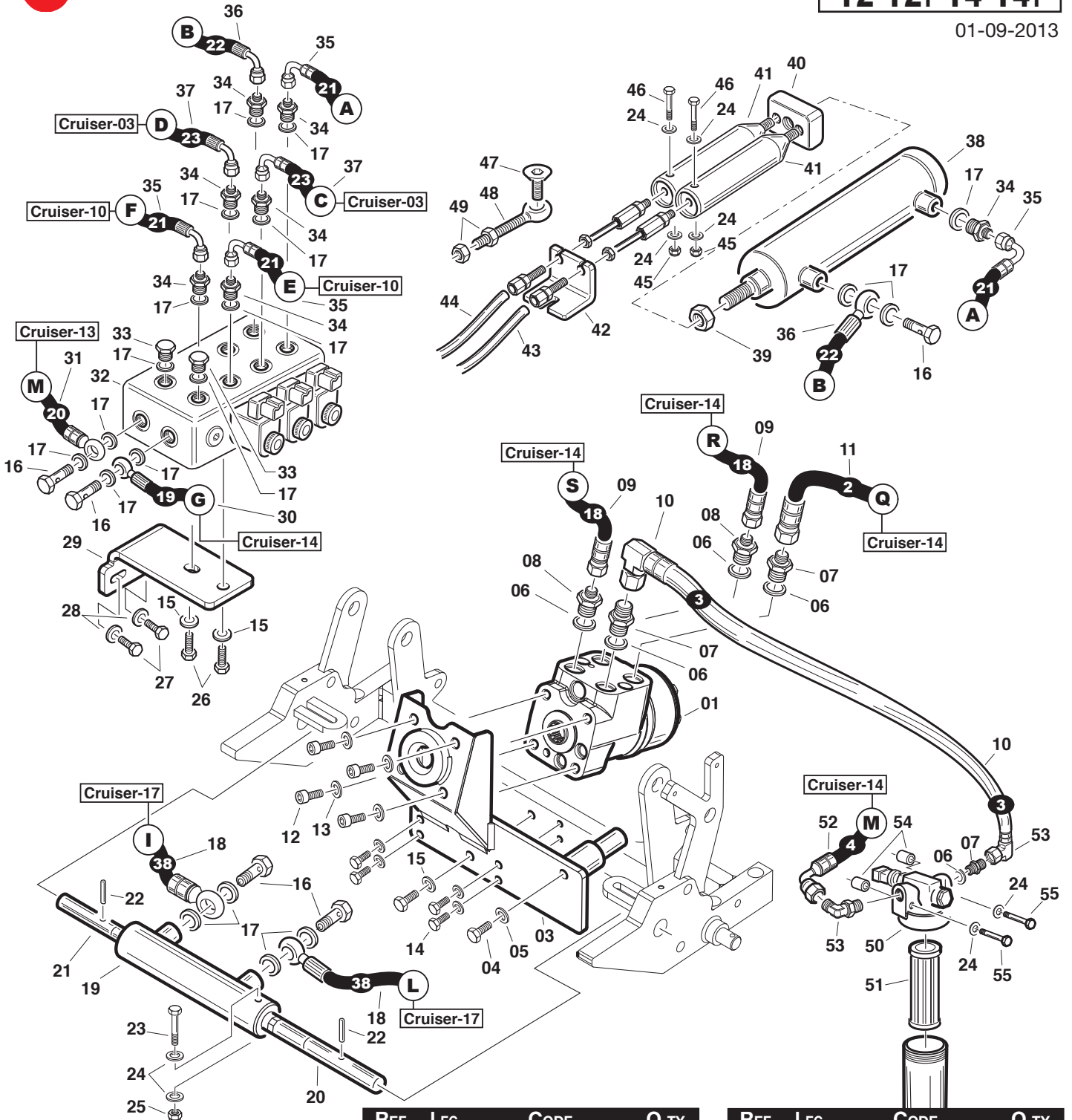

REF.	LEG.	CODE	Q.TY
1		00.41.00.3680	1
2		01.40.00.0362	1
3		01.50.00.0189	1
4		00.92.06.1040	1
5		00.68.01.0040	1
6		00.41.00.0071	5
7		00.41.00.0113	3
8		00.41.00.0783	2
9		00.41.00.3867	2
10		00.41.00.3849	1
11		00.41.00.3851	1
12		00.90.07.0080	4
13		00.68.12.0010	4
14		00.92.05.1100	4
15		00.68.01.0030	6
16		00.41.00.0120	5
17		00.41.00.0060	19
18		00.41.00.3887	2

REF.	LEG.	CODE	Q.TY
19		00.58.00.0260	1
20		01.40.00.0359	1
21		01.40.00.0361	1
22		00.83.14.0036	2
23		00.92.03.0170	1
24		00.68.01.0020	8
25		00.26.04.0040	1
26		00.92.05.1040	2
27		00.92.03.1040	2
28		00.68.02.0030	2
29		01.60.00.0637	1
30		00.41.00.3868	1
31		00.41.00.3869	1
32		00.41.00.1502	1
33		00.85.02.0002	2
34		00.41.00.0780	7
35		00.41.00.3870	3
36		00.41.00.3871	1
37		00.41.00.3872	2

REF.	LEG.	CODE	Q.TY
38		00.58.00.0250	1
39		00.26.03.1110	1
40		01.60.00.0296	1
41		01.50.00.5580	2
42		01.60.00.0297	1
43		00.25.01.0110	1
44		00.25.01.0095	1
45		00.26.05.0040	2
46		00.92.03.1110	2
47		00.95.06.0080	1
48		00.99.00.0064	1
49		00.26.02.0080	2
50		00.32.03.0020	1
51		00.32.03.0010	1
52		00.41.00.3853	1
53		00.41.00.0876	2
54		01.40.00.0491	2
55		00.92.03.0210	2



Gianni Ferrari

1160077

Cruiser-16

T2-T2T-T4-T4T

01-09-2013

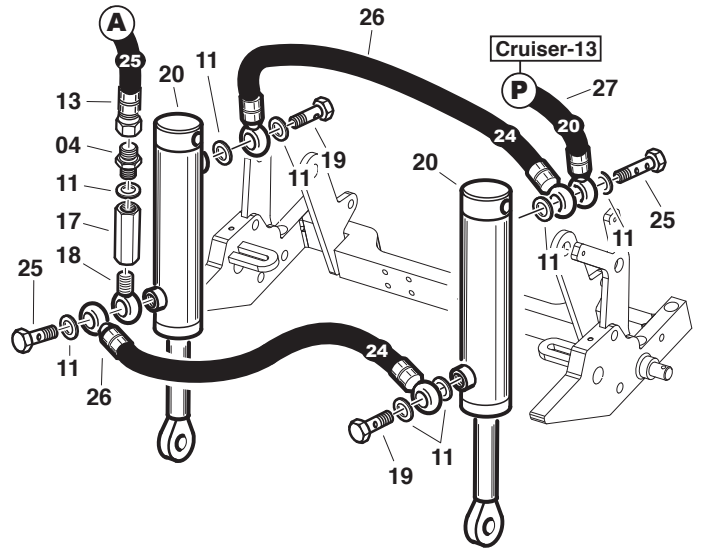
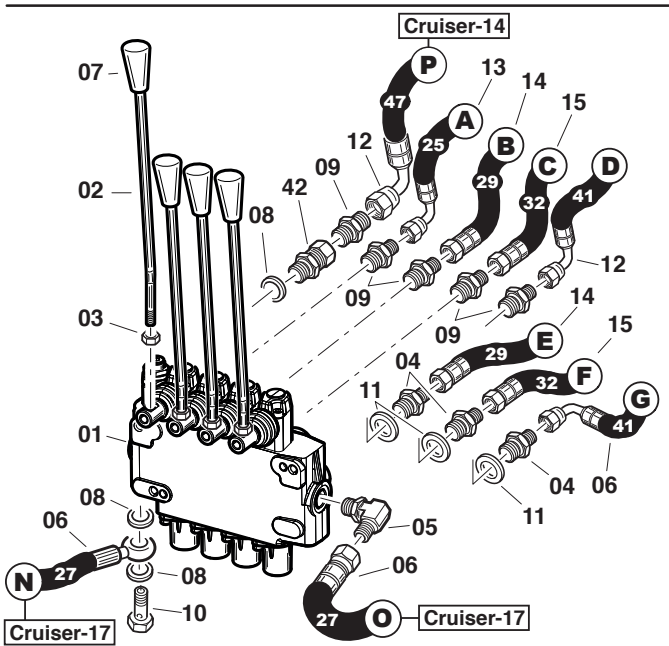
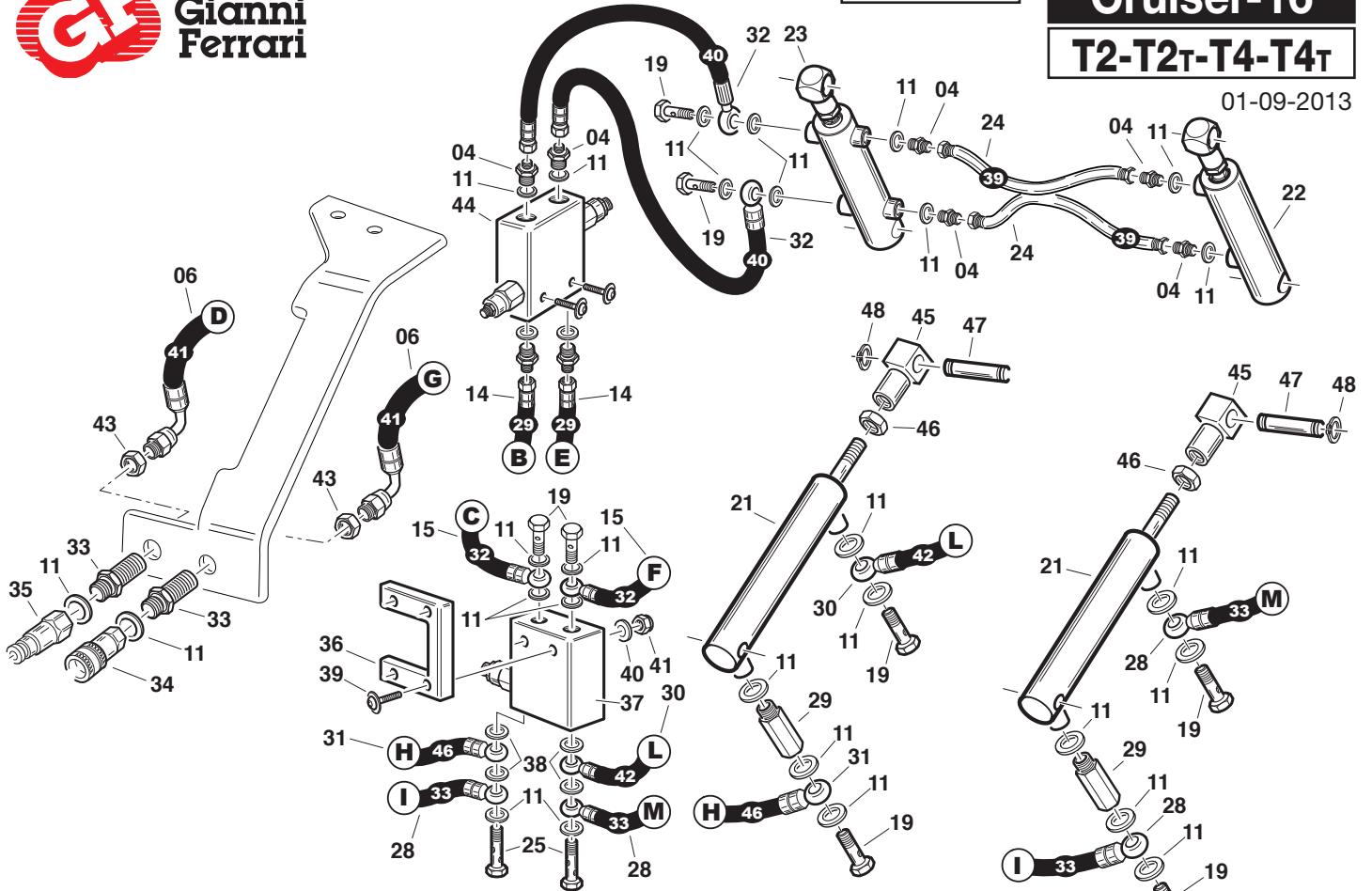

REF.	LEG.	CODE	Q.TY
1		00.41.00.2560	1
2		01.40.00.1225	4
3		00.26.02.0060	4
4		00.41.00.0450	7
5		00.41.00.0875	1
6		00.41.00.3875	2
8		00.41.00.0070	3
9		00.41.00.0114	1
10		00.41.00.0250	1
11		00.41.00.0060	41
12		00.41.00.3895	1
13		00.41.00.3873	1
14		00.41.00.3878	2
15		00.41.00.3881	2
16		00.41.00.3877	1

REF.	LEG.	CODE	Q.TY
17		00.41.00.0291	1
18		00.41.00.3681	1
19		00.41.00.0120	8
20		00.58.00.0100	2
21		00.58.00.0015	2
22		00.58.00.0027	1
23		00.58.00.0029	1
24		00.41.00.3888	2
25		00.41.00.0124	4
26		00.41.00.1670	2
27		00.41.00.3869	1
28		00.41.00.3882	1
29		00.41.00.3812	2
30		00.41.00.3890	1
31		00.41.20.0040	1

REF.	LEG.	CODE	Q.TY
32		00.41.00.3889	2
33		00.41.00.0360	2
34		00.41.00.0460	1
35		00.41.00.0470	1
36		01.60.00.0344	1
37		00.41.00.3712	1
38		00.41.00.0062	4
39		00.90.04.3150	2
40		00.68.01.0030	2
41		00.26.04.0060	2
42		00.41.00.2212	1
43		00.41.00.0370	2
45		01.90.00.0540	4
46		00.26.03.1110	4

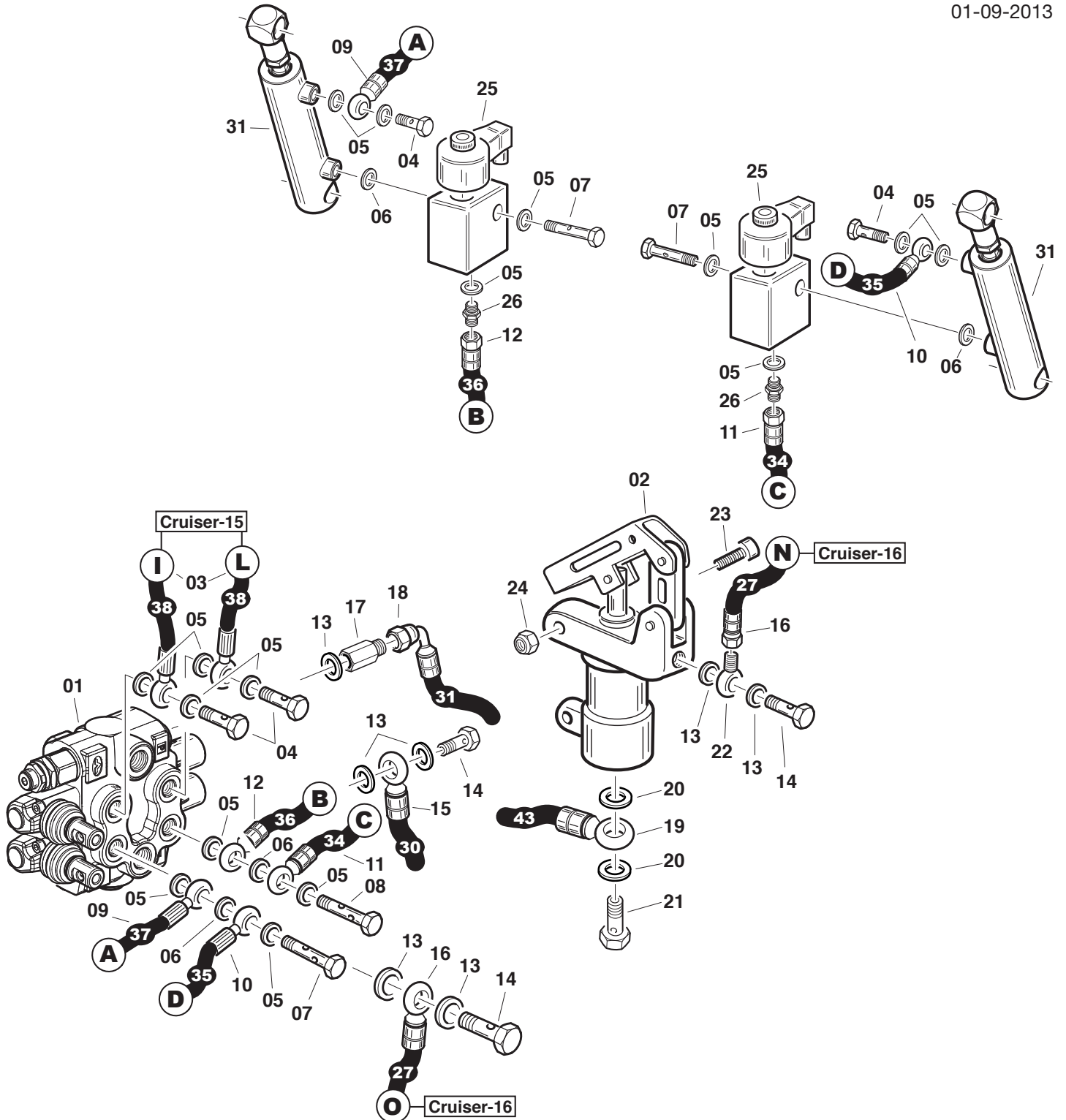

REF.	LEG.	CODE	Q.TY
1		00.41.00.2550	1
2		00.41.00.3840	1
3		00.41.00.3887	2
4		00.41.00.0120	4
5		00.41.00.0060	4
6		00.41.00.0062	4
7		00.41.00.0124	3
8		00.41.00.0123	1
9		00.41.00.3886	1

REF.	LEG.	CODE	Q.TY
10		00.41.00.3884	1
11		00.41.00.3883	1
12		00.41.00.3885	1
13		00.41.00.0070	5
14		00.41.00.0250	2
15		00.41.00.3879	1
16		00.41.00.3875	1
17		00.41.00.3813	1
18		00.41.00.3880	1

REF.	LEG.	CODE	Q.TY
19		00.41.00.3897	1
20		00.41.00.0071	2
21		00.41.00.0125	1
22		00.41.00.0242	1
23		00.92.05.0120	1
24		00.26.05.0060	1
25		00.41.00.3710	2
26		00.41.00.0450	2
31		00.58.00.0025	2

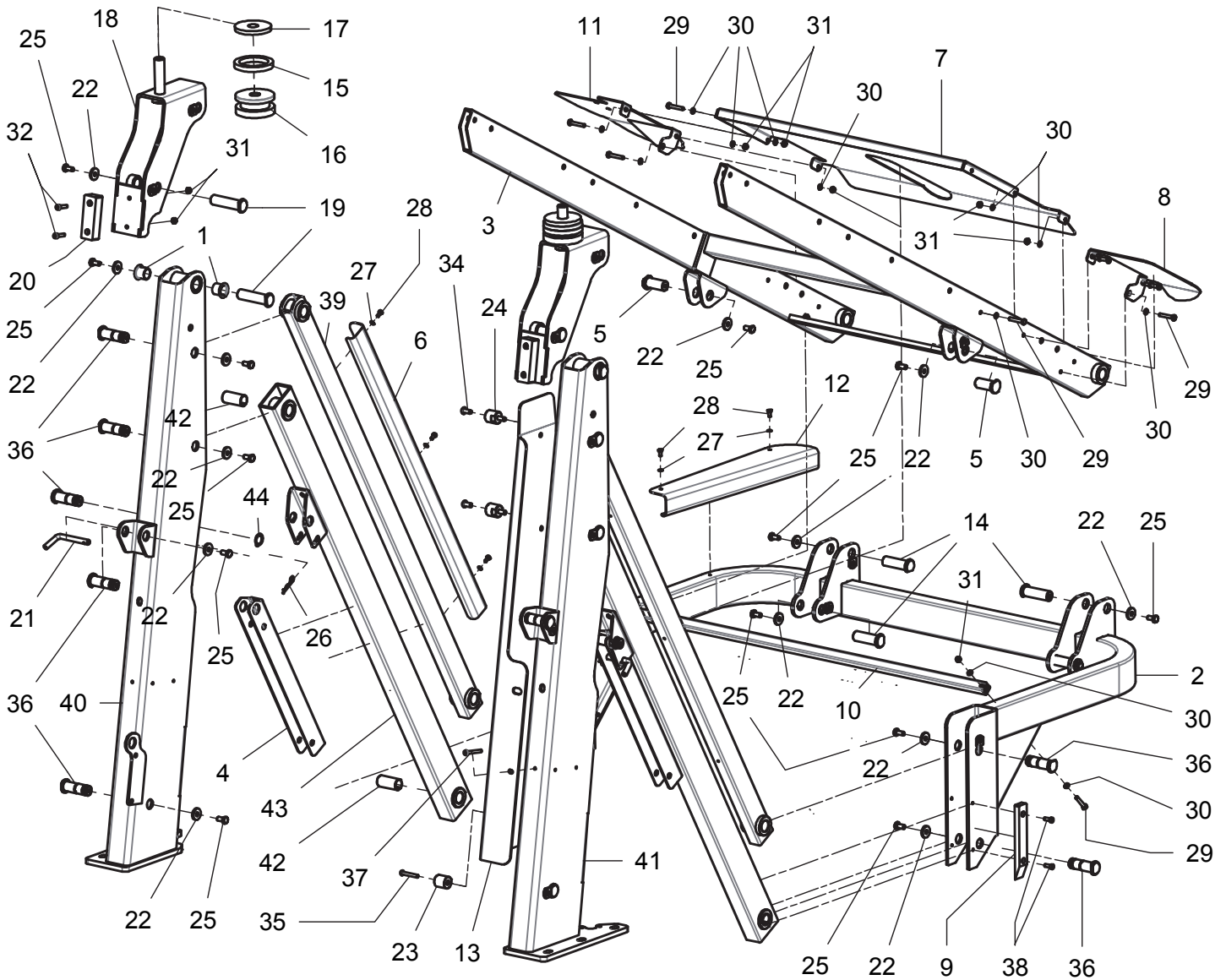

Ref.	Leg.	Code	Q.ty	Ref.	Leg.	Code	Q.ty	Ref.	Leg.	Code	Q.ty
1		00.10.20.0020	4	15		01.60.00.0225	2	29		00.92.03.1120	10
2		01.50.00.0145	1	16		00.07.01.0212	2	30		00.68.01.0020	20
3		01.50.00.0194	1	17		01.60.00.0227	2	31		00.26.05.0040	14
4		01.60.00.0560	2	18		01.50.00.0147	2	32		00.90.04.0100	4
5		01.40.20.0146	2	19		01.40.00.0350	4	33		00.03.10.0020	2
6		01.60.00.0554	1	20		00.07.01.0213	2	34		00.90.06.3060	2
7		01.50.00.0162	1	21		01.50.00.2441	2	35		00.90.04.3130	1
8		01.50.00.0164	1	22		00.68.08.0170	20	36		01.50.00.2310	14
9		00.07.01.0214	2	23		01.40.00.0349	1	37		00.90.04.3150	1
10		01.60.00.0577	1	24		01.40.00.2742	2	38		00.90.04.0060	4
11		01.50.00.0163	1	25		00.92.05.1040	20	39		01.50.00.0131	2
12		01.60.00.0580	1	26		00.18.00.1010	2	40		01.50.00.0127	1
13		01.60.00.0643	1	27		00.68.01.0010	5	41		01.50.00.0128	1
14		01.40.00.0373	4	28		00.92.02.1020	5	42		00.10.20.0048	4
								43		01.50.00.0129	2
								44		01.03.10.0020	1



Gianni Ferrari

Cruiser-13

1152084

Cruiser-19

T2-T2T-T4-T4T

01-09-2013

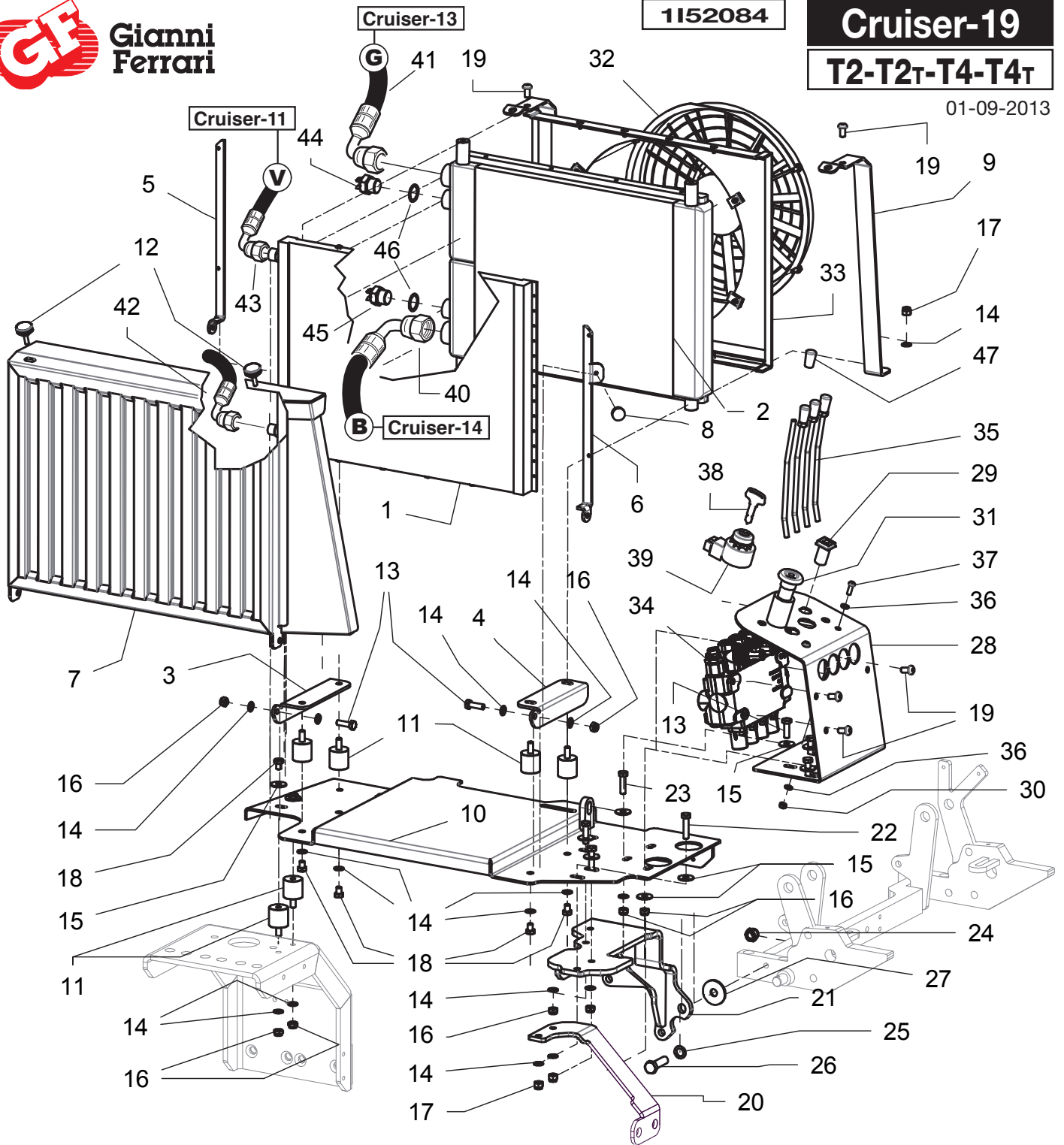

Ref.	Leg.	Code	Q.ty	Ref.	Leg.	Code	Q.ty	Ref.	Leg.	Code	Q.ty
1		00.54.10.0120	1	17		00.26.04.0060	4	33		01.30.00.0642	1
2		00.54.10.0028	1	18		00.92.05.1010	6	34		00.41.00.0190	1
3		01.60.00.0232	1	19		00.90.06.3060	5	35		01.40.00.1225	4
4		01.60.00.0233	1	20		01.60.00.0572	1	36		00.68.01.0020	4
5		01.60.00.0298	1	21		01.50.00.0187	1	37		00.90.04.3070	2
6		01.60.00.0299	1	22		00.92.05.1110	2	38		00.40.00.0091	1
7		01.50.00.0139	1	23		00.92.05.1100	2	39		00.55.01.0091	1
8		00.74.00.0017	1	24		00.26.05.0080	1	40		00.41.00.3857	1
9		01.50.01.2757	2	25		00.68.01.0050	1	41		00.41.00.3858	1
10		01.50.00.0188	1	26		00.92.07.1090	1	42		00.99.00.0703	1
11		00.74.03.0070	6	27		00.68.08.0346	1	43		00.99.00.0701	1
12		00.45.01.0036	2	28		01.50.00.0184	1	44		00.54.10.0054	1
13		00.92.05.1080	5	29		00.40.00.0190	1	45		00.54.10.0053	1
14		00.68.01.0030	18	30		00.26.02.0040	2	46		00.41.00.0216	2
15		00.68.02.0050	10	31		00.40.00.2235	1	47		00.07.03.0010	4
16		00.26.05.0060	9	32		01.30.00.0643	1	48		00.26.02.0060	4

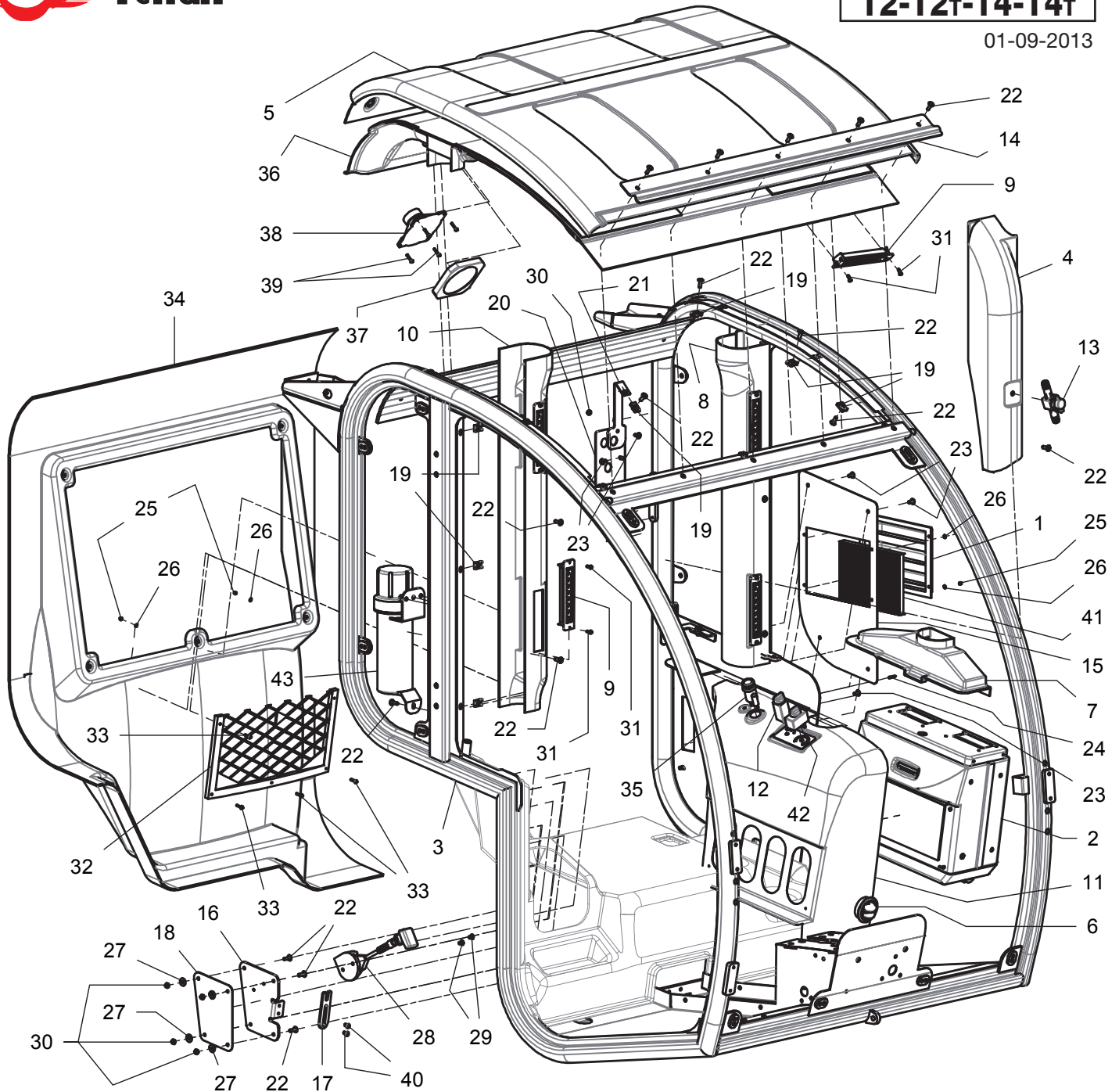

Ref.	Leg.	Code	Q.ty	Ref.	Leg.	Code	Q.ty	Ref.	Leg.	Code	Q.ty
1		00.99.00.0600	1	15		01.60.00.0607	1	29		00.95.04.0020	2
2		00.99.00.0601	1	16		01.50.00.0165	1	30		00.26.05.0040	5
3		01.50.00.0136	1	17		01.60.00.0574	1	31		00.94.06.3050	12
4		01.30.00.0940	1	18		01.60.00.0576	1	32		00.07.01.0040	1
5		01.30.00.0870	1	19		00.99.00.0012	22	33		00.91.04.0070	5
6		00.99.00.0602	1	20		01.50.00.0150	1	34		01.30.00.0860	1
7		01.30.00.0950	1	21		01.60.00.0371	1	35		00.99.00.0276	1
8		01.30.00.0890	1	22		00.90.04.3070	35	36		01.90.00.0036	1
9		00.99.00.0603	6	23		00.90.04.3040	12	37		00.40.00.2519	2
10		01.30.00.0900	1	24		00.96.02.2025	4	38		00.40.00.2520	2
11		01.30.00.0880	1	25		00.26.04.0020	9	39		00.91.04.0080	8
12		00.99.00.0605	1	26		00.68.01.0009	9	40		00.90.04.3030	2
13		00.99.00.0606	1	27		00.68.02.0030	4	41		00.32.20.0014	1
14		01.50.00.0166	1	28		01.90.00.0047	1	42		00.99.00.0604	1
								43		01.30.00.0435	1

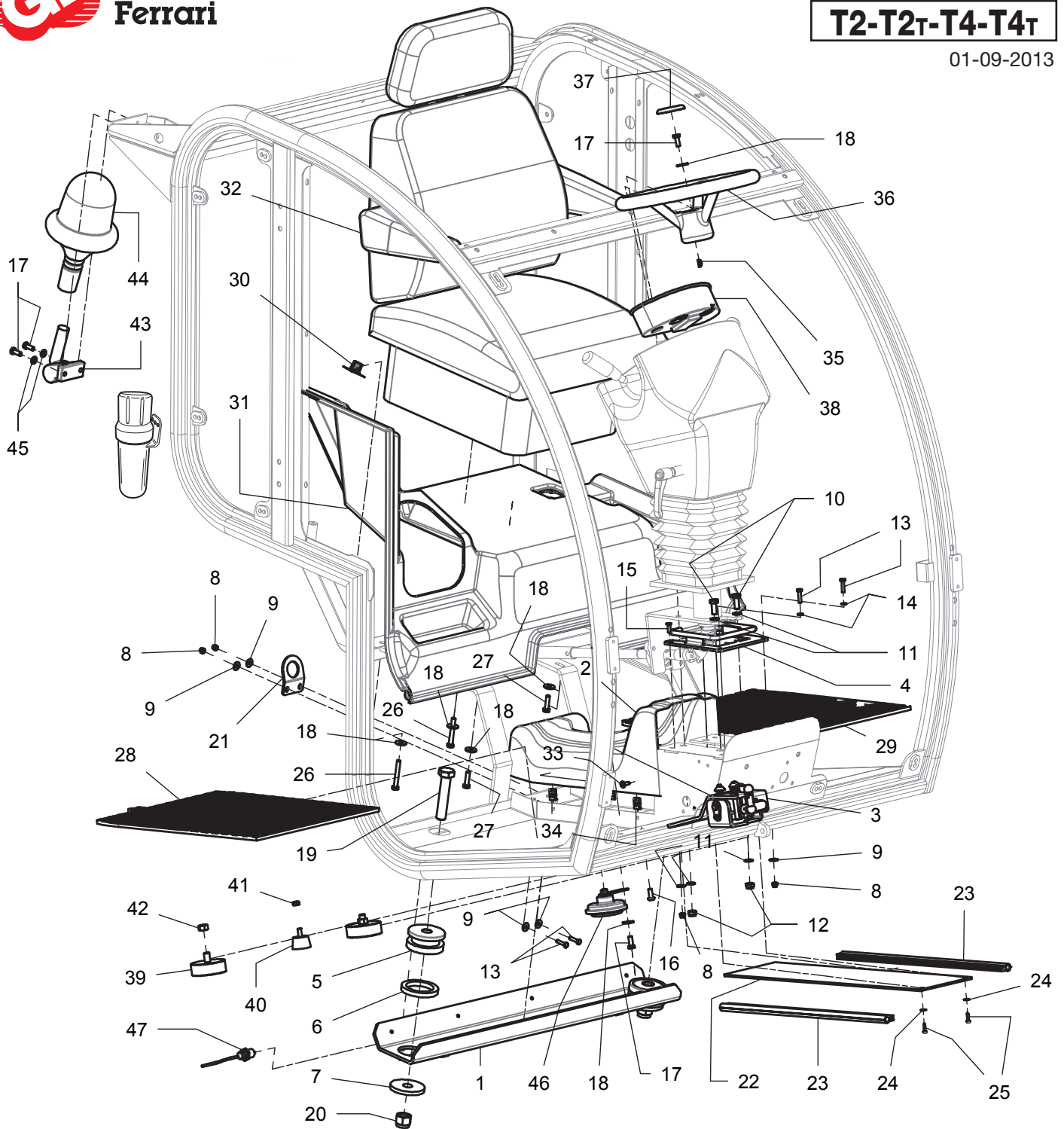

Ref.	Leg.	Code	Q.ty	Ref.	Leg.	Code	Q.ty	Ref.	Leg.	Code	Q.ty
1		01.50.00.0146	1	17		00.92.05.1070	4	33		00.90.04.3070	4
2		01.30.00.0910	1	18		00.68.02.0050	6	34		00.99.00.0012	4
3		01.90.00.0980	1	19		00.92.11.0150	2	35		00.43.05.0090	1
4		01.50.01.2762	1	20		00.26.04.0120	2	36		00.25.03.0020	1
5		00.07.01.0212	2	21		01.60.00.0342	1	37		00.25.03.0021	1
6		01.60.00.0225	2	22		01.30.00.0030	1	38		00.40.00.2350	1
7		01.60.00.0227	2	23		00.11.01.2000	2	39		00.07.01.0211	2
8		00.26.04.0040	6	24		00.68.02.0010	2	40		00.74.00.0030	1
9		00.68.02.0030	9	25		00.94.06.3050	2	41		00.26.02.0060	1
10		00.92.06.1060	4	26		00.92.05.0160	2	42		00.26.02.0090	2
11		00.68.01.0040	7	27		00.92.05.1100	2	43		00.40.00.2010	1
12		00.26.05.0070	4	28		01.29.00.0094	1	44		00.40.00.0490	1
13		00.92.03.1090	4	29		01.29.00.0092	1	45		00.92.05.1070	2
14		00.68.01.0020	2	30		00.40.00.0298	1	46		00.40.00.0241	1
15		00.95.04.0060	2	31		01.30.00.0850	1	47		00.40.00.0944	1
16		00.90.06.3080	1	32		00.73.00.0030	1				

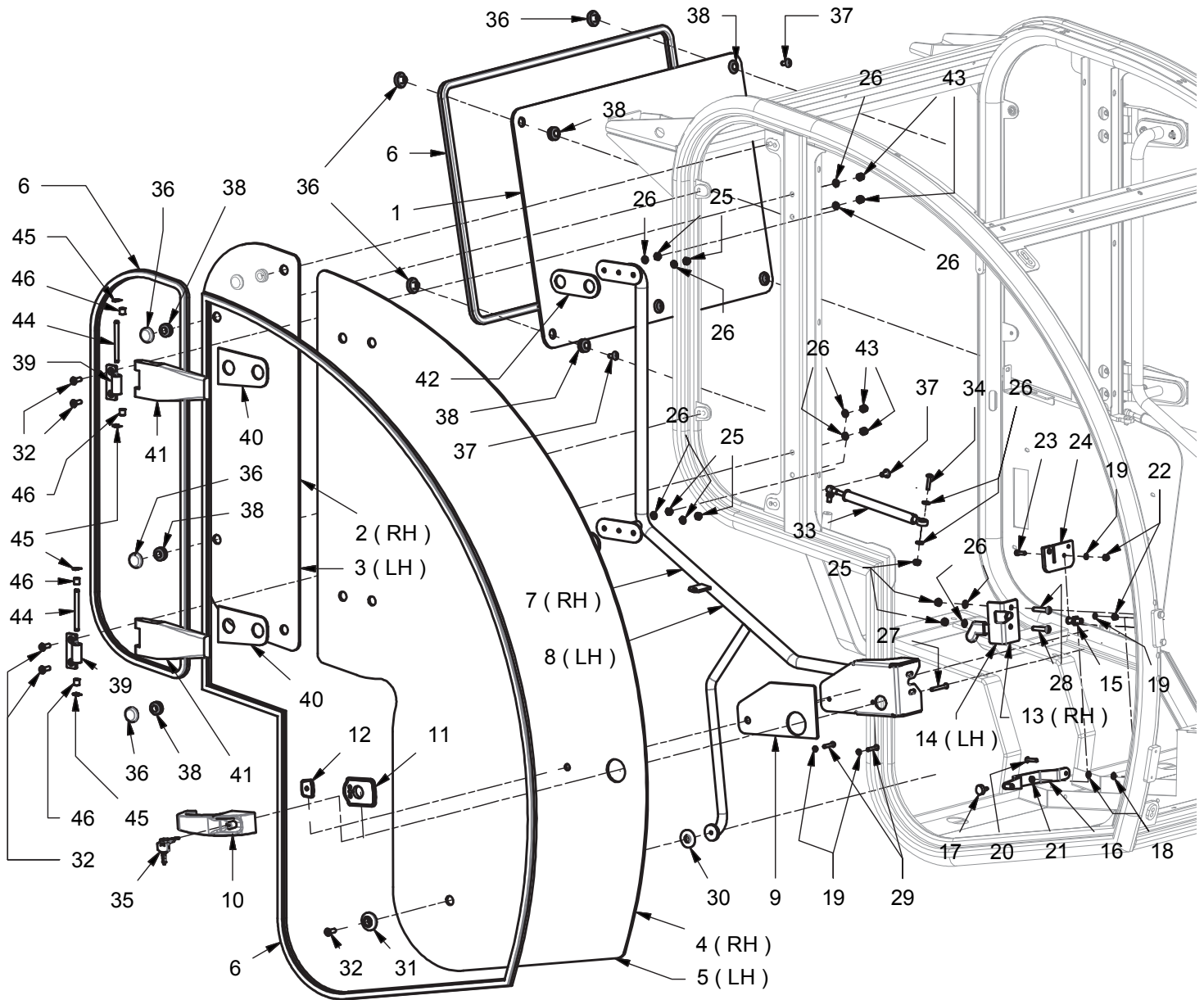

Ref.	Leg.	Code	Q.ty	Ref.	Leg.	Code	Q.ty	Ref.	Leg.	Code	Q.ty
1		00.99.01.0016	1	16		01.50.00.0091	2	31		00.07.01.0043	2
2	RH	00.99.01.0014	1	17		00.74.00.0017	2	32		00.95.05.0060	10
3	LH	00.99.01.0015	1	18		00.68.12.0008	4	33		01.90.00.0039	2
4	RH	00.99.01.0013	1	19		00.68.01.0020	8	34		00.90.04.3070	2
5	LH	00.99.01.0012	1	20		00.90.04.3100	2	35		00.99.00.0261	2
6		00.11.01.0014	17	21		00.26.02.0040	2	36		00.45.00.0116	13
7	LH	01.50.00.0134	1	22		00.26.04.0040	4	37		00.90.04.3040	13
8	DH	01.50.00.0135	1	23		00.90.04.0070	2	38		00.07.01.0038	13
9		00.07.01.0240	2	24		01.60.00.0948	2	39		01.50.01.4620	4
10		00.44.01.0050	2	25		00.26.05.0060	14	40		00.07.01.0250	4
11		00.44.01.0051	2	26		00.68.01.0030	26	41		00.99.00.0310	4
12		00.44.01.0052	2	27		00.90.04.3150	2	42		00.99.00.0314	4
13	RH	00.99.00.0260	1	28		00.90.06.3130	4	43		00.26.04.0060	8
14	LH	00.99.00.0270	1	29		00.90.04.3110	4	44		00.99.00.0311	4
15		01.60.00.0278	2	30		00.07.01.0042	2	45		00.99.00.0312	8
								46		00.99.00.0313	8

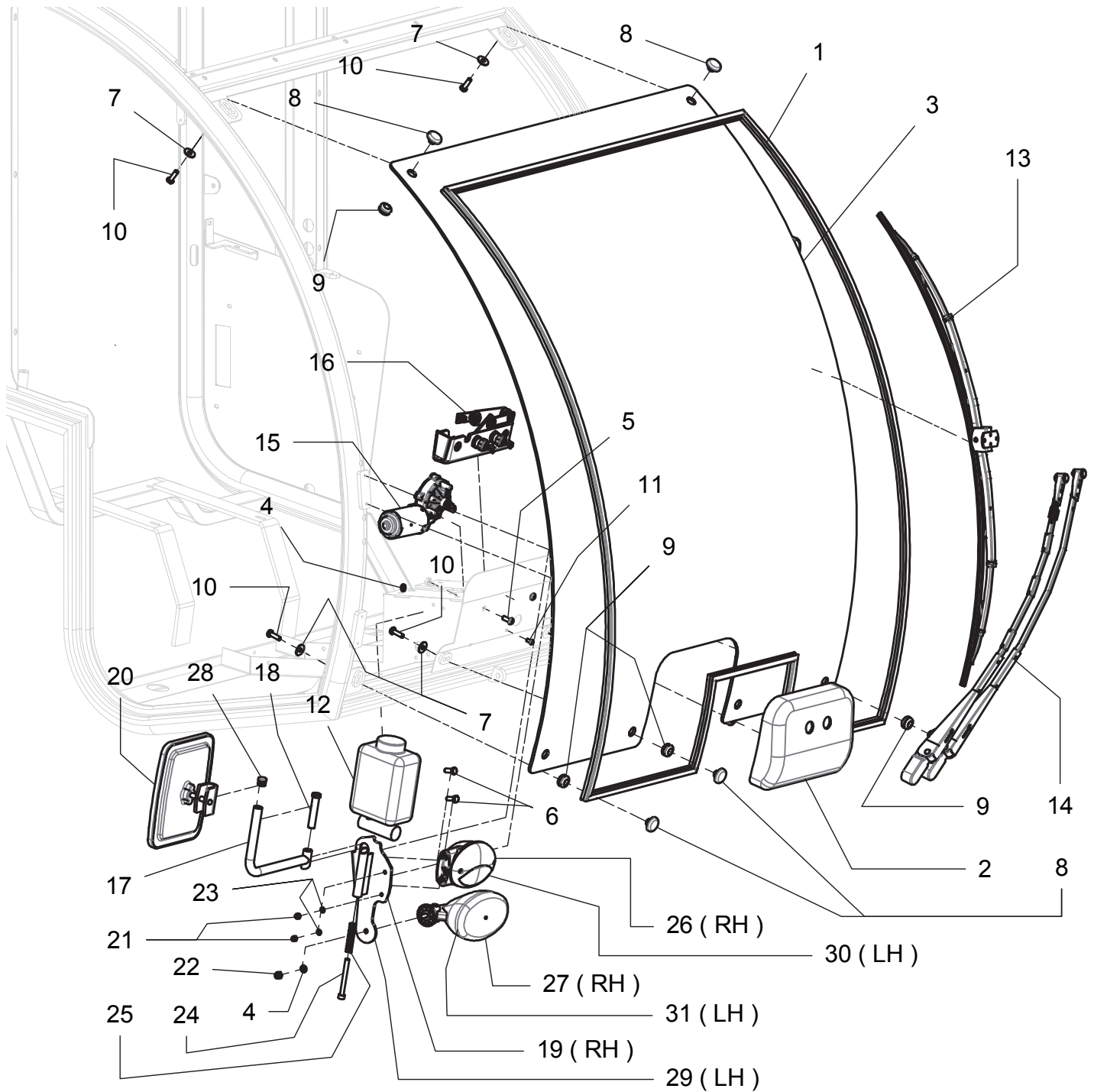

Ref.	Leg.	Code	Q.ty	Ref.	Leg.	Code	Q.ty	Ref.	Leg.	Code	Q.ty
1		00.11.01.0014	3,5	11		00.90.04.3040	3	21		00.26.04.0040	4
2		01.30.00.0960	1	12		00.75.00.0122	1	22		00.26.04.0060	2
3		00.99.01.0011	1	13		00.54.00.2060	1	23		00.68.01.0020	4
4		00.68.01.0030	6	14		00.54.00.2062	1	24		00.90.06.0210	2
5		00.90.06.3080	2	15		00.54.00.2063	1	25		00.47.00.0505	2
6		00.92.05.1070	4	16		00.54.00.2061	1	26	RH	00.40.00.1260	1
7		00.68.02.0050	6	17		01.50.00.0148	2	27	RH	00.40.00.1280	1
8		00.45.00.0116	6	18		01.40.00.0355	2	28		00.07.01.0015	2
9		00.07.01.0038	6	19	RH	01.50.00.0149	1	29	LH	01.50.00.0169	1
10		00.92.05.1080	6	20		00.99.00.0205	2	30	LH	00.40.00.1270	1
								31	LH	00.40.00.1281	1



Advanced Groundcare Solutions™

